



# Hazloc Heaters™



Safe heat when you need it!

## XEU1

### Electric Forced-Air Explosion-Proof Heater Owner's Manual, Version: XEU1-OM-J

This manual covers installation, maintenance,  
repair, and replacement parts.



## Forced-Air Heater for Hazardous Locations



Class I, Division 1 & 2, Groups C & D  
Class II, Division 1 & 2, Groups F & G  
Temperature Code T3B (3kW/35kW = T3A)

Class I, Zone 1 & 2, Groups IIA & IIB, T3



235730

### WARNING!

Please adhere to all instructions published in this manual.  
Failure to do so may be dangerous and may void your warranty.

**Note:** XEU1 heaters **must** not be exposed to rain or snow. This applies to installed & stored heaters.  
The XEU1 heater should not be modified in any way.

[www.HazlocHeaters.com](http://www.HazlocHeaters.com)

# XEU1 Model Coding on Data Plate



## Full Model Code & Option Sequence

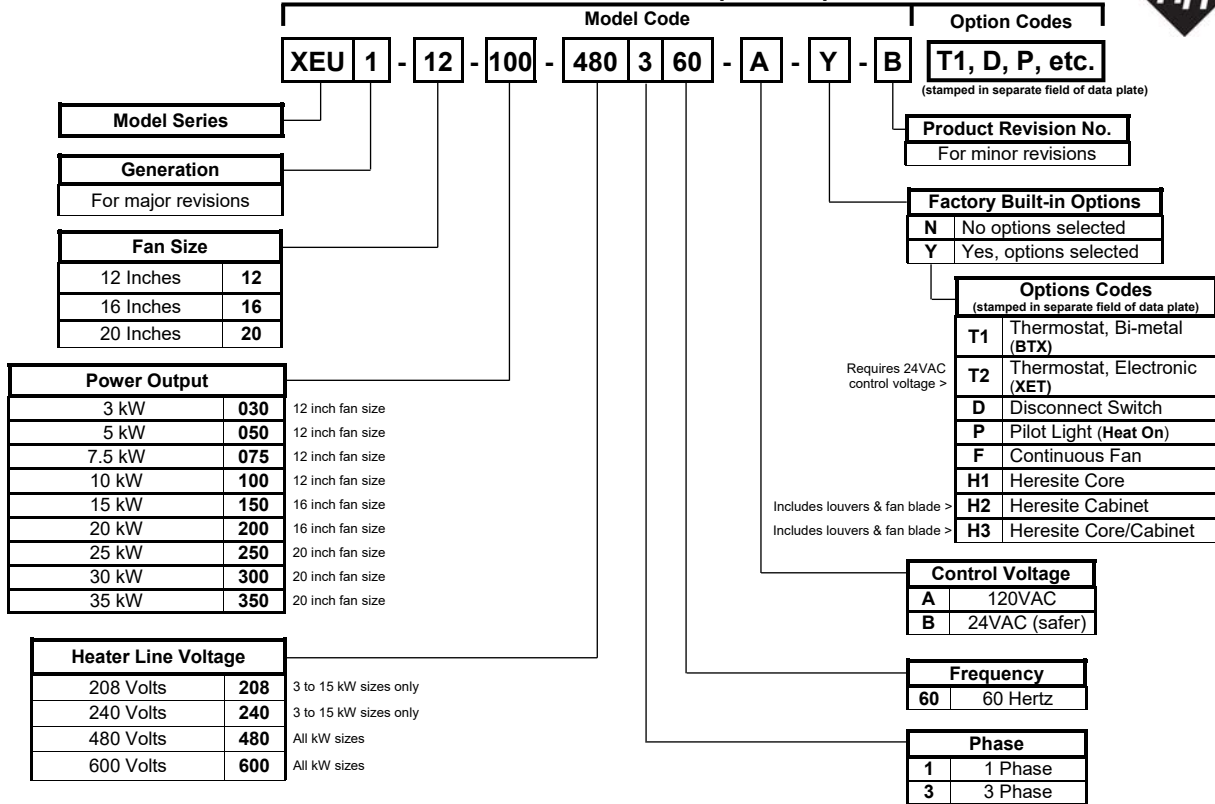

## XEU1 Physical Dimensions

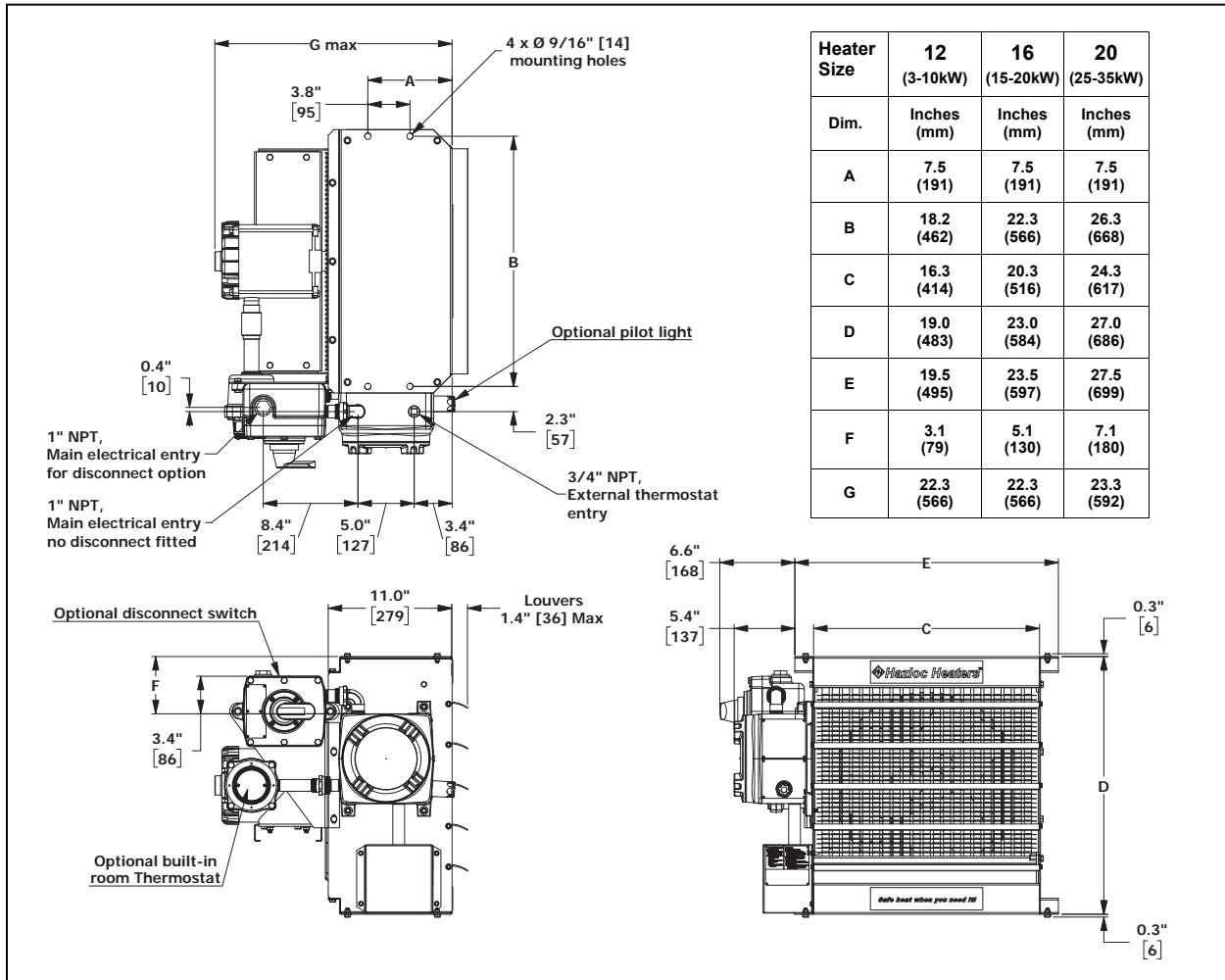

## XEU1 Specifications By Model Size

| Model                                               |                      | XEU1-12    |     |      |            | XEU1-16     |      | XEU1-20     |      |    |
|-----------------------------------------------------|----------------------|------------|-----|------|------------|-------------|------|-------------|------|----|
| Fan Diameter                                        | in. (mm)             | 12 (304.8) |     |      |            | 16 (406.4)  |      | 20 (508.0)  |      |    |
| Nominal kW                                          |                      | 3          | 5   | 7.5  | 10         | 15          | 20   | 25          | 30   | 35 |
| Air Delivery                                        | CFM                  | 350        | 400 | 600  | 800        | 1200        | 1700 | 2100        | 3000 |    |
|                                                     | m <sup>3</sup> /hr   | 595        | 680 | 1019 | 1359       | 2039        | 2888 | 3568        | 5097 |    |
| Approx. Air Velocity                                | FPM                  | 422        | 479 | 718  | 958        | 808         | 1145 | 916         | 1309 |    |
|                                                     | m/s                  | 2.1        | 2.4 | 3.6  | 4.9        | 4.1         | 5.8  | 4.6         | 6.6  |    |
| Approx. Horizontal Air Throw                        | ft                   | 13         | 15  | 22   | 30         | 33          | 46   | 41          | 61   |    |
|                                                     | m                    | 3.9        | 4.6 | 6.7  | 9.1        | 10.1        | 14.0 | 12.5        | 18.6 |    |
| Motor Power                                         | HP (Watts)           | ¼ (186)    |     |      |            | ¼ (186)     |      | ½ (373)     |      |    |
| Maximum Mounting Height<br>(to underside of heater) | ft                   | 7          | 7   | 7.5  | 9.5        | 10          | 11   | 12          | 15   |    |
|                                                     | m                    | 2.1        | 2.1 | 2.3  | 2.9        | 3.0         | 3.4  | 3.6         | 4.6  |    |
| Approx. Net Weight<br>Lbs (kg)                      | (without disconnect) | 129 (58.5) |     |      | 133 (60.3) | 161 (73.0)  |      | 192 (87.1)  |      |    |
|                                                     | (with disconnect)    | 142 (64.4) |     |      | 146 (66.2) | 174 (78.9)  |      | 205 (92.9)  |      |    |
| Approx. Shipping Weight<br>Lbs (kg)                 | (without disconnect) | 188 (85.3) |     |      | 192 (87.1) | 224 (101.6) |      | 261 (118.4) |      |    |
|                                                     | (with disconnect)    | 201 (91.2) |     |      | 205 (93.0) | 237 (107.5) |      | 274 (124.3) |      |    |

## XEU1 General Specifications

|                    |                                                                       |                                                                                                                                                                                                                                                                                                                  |
|--------------------|-----------------------------------------------------------------------|------------------------------------------------------------------------------------------------------------------------------------------------------------------------------------------------------------------------------------------------------------------------------------------------------------------|
| Approvals          | Certification                                                         | cCSAus 235730 - Certified to Canadian and U.S. standards.                                                                                                                                                                                                                                                        |
|                    | North American Hazardous Location Classifications                     | Class I, Division 1 & 2, Groups C & D<br>Class II, Division 1 & 2, Groups F & G<br>Temperature Code T3B (3kW/35kW =T3A)<br><br>Class I, Zone 1 & 2, Groups IIA & IIB, T3                                                                                                                                         |
|                    | Temperature Code                                                      | Division System - T3B 165°C (329°F); [3kW/35kW = T3A 180°C (356°F)]<br>Zone System - T3 200°C (392°F)                                                                                                                                                                                                            |
| Cabinet            | Cabinet Material                                                      | 14-gauge (0.075 in.) (1.9 mm) steel. Yellow epoxy/polyester powder coated with five-stage pretreatment, including iron phosphate.                                                                                                                                                                                |
|                    | Fan Guard                                                             | Split design with close wire spacing. A 3/8 in. (9.5 mm) diameter probe will not enter. Black polyester powder coated.                                                                                                                                                                                           |
|                    | Louver Blades                                                         | Anodized extruded aluminum.                                                                                                                                                                                                                                                                                      |
|                    | Conduit Materials & Fittings                                          | Plated steel and aluminum alloy for corrosion resistance.                                                                                                                                                                                                                                                        |
|                    | Fasteners                                                             | Zinc plated steel for corrosion resistance.                                                                                                                                                                                                                                                                      |
|                    | Enclosures                                                            | Cast aluminum (non-copper alloy) NEMA Type 7 & 9 with O-ring.                                                                                                                                                                                                                                                    |
|                    | Mounting Holes                                                        | 9/16" diameter holes – Four located on the top face of heater.                                                                                                                                                                                                                                                   |
| Motor/Fan          | Motor Type                                                            | Explosion-proof, thermally protected, 1725 RPM permanently lubricated ball bearing type with 56 frame and "easy-off" fan blade replacement feature.                                                                                                                                                              |
|                    | Fan                                                                   | Three-blade aluminum, steel spider and hub with 5/8 in. bore                                                                                                                                                                                                                                                     |
| Heat Exchanger     | Heating Elements                                                      | Long-life, low watt-density, high grade metal-sheathed elements.                                                                                                                                                                                                                                                 |
|                    | Heat Transfer Fluid                                                   | Ethylene glycol and water including corrosion inhibitors.                                                                                                                                                                                                                                                        |
|                    | Header Material                                                       | Carbon steel.                                                                                                                                                                                                                                                                                                    |
|                    | ExCaliber™ Core                                                       | Carbon steel headers and element housing with O-ring. Fin tubes are carbon steel tubes with copper-free, roll-formed aluminum fins @ 10 fins per in. Vacuum sealed. Coated with black, high-heat enamel.                                                                                                         |
| Protection         | Temperature High Limits                                               | One automatic reset rated for 100,000 cycles, and one manual reset. Both are snap-action bimetal type, open on temperature rise.                                                                                                                                                                                 |
|                    | Pressure Relief                                                       | High-quality stainless steel pressure relief device.                                                                                                                                                                                                                                                             |
| Controls           | Control Circuit                                                       | Built-in 120VAC or 24VAC control (24VAC recommended).                                                                                                                                                                                                                                                            |
|                    | Control Contactor                                                     | 40 FLA (50A resistive per pole) Definite Purpose. Rated for 500,000 mechanical operations.                                                                                                                                                                                                                       |
|                    | Control Transformer                                                   | Multitap primary, 120VAC or 24VAC secondary.                                                                                                                                                                                                                                                                     |
|                    | Fuse Protection                                                       | Thermal delay fuse with spare, .25" x 1.25" , 120VAC = 1/4A, 24VAC = 1A.                                                                                                                                                                                                                                         |
|                    | Room Thermostat With Lockable Temperature Dial (option code T1 or T2) | Built-in, BTX (T1) or XET (T2) explosion-proof thermostat, 40°F to 80°F (5°C to 25°C). Conduit is factory sealed between enclosures. Wall mount versions also available.<br><b>Note:</b> Optional BLK1 thermostat conversion kit allows simple interchangeability from a built-in to a wall mount configuration. |
| Load Isolation     | Disconnect Switch (option code D)                                     | Built-in, XDC-01 explosion-proof disconnect switch, 600VAC, 50A max with lock-out feature. Conduit is factory sealed between enclosures. Wall mount disconnect available.                                                                                                                                        |
| Additional Options | Pilot Light (option code P)                                           | Built-in "Heat on" Green LED pilot light with lens guard.                                                                                                                                                                                                                                                        |
|                    | Continuous Fan (option code F)                                        | Continuous fan operation. Circulates air and prevents gas pockets from forming.                                                                                                                                                                                                                                  |
|                    | Heresite Coating (option code H1, H2, H3)                             | H1 = Heresite Core; or H2 = Heresite Cabinet (includes louvers & fan blade); or H3 = Heresite Core and Cabinet. Note: Contact factory for Heresite delivery lead time.                                                                                                                                           |
| Operating Limits   | Ambient Temperature                                                   | -40°F to 104°F (-40°C to 40°C). Storage: -58°F to 140°F (-50°C to 60°C)                                                                                                                                                                                                                                          |
|                    | Maximum Altitude                                                      | 10,000 ft (3048 m) above sea level.                                                                                                                                                                                                                                                                              |

**— WARNING! —**

**Read and follow the instructions in this manual. Failure to do so may result in severe or fatal injury.**

**IMPORTANT SAFETY INFORMATION**

1. Heater is to be connected and serviced only by qualified electrician experienced with hazardous location equipment. It is the responsibility of the installer to verify the safety and suitability of the installation.
2. Installation and wiring of the heater must adhere to all applicable codes. Heater must be effectively grounded to eliminate shock hazard.
3. Heater is to be used only in atmospheres having an ignition temperature higher than the heater's maximum rated operating temperature as shown on the heater data plate. For details of hazardous locations with potential for explosion, refer to the Canadian Electrical Code, Part 1, Section 18 or Articles 500 through 516 of the National Electrical Code.
4. Do not operate heater in ambient temperatures above 40°C (104°F).
5. Do not plug heater outlet with gloves, clothing, etc. or operate heater with louvers fully closed.
6. **Explosion/Electric Shock Hazard.** Disconnect heater from power supply or fuse box before opening enclosures or servicing heater. Lock the switch in the "OFF" (open) position and/or tag the switch to prevent unexpected power application.
7. Operate the heater only while it is permanently mounted in an upright position. Failure to comply will cause overheating of the heat exchanger and shutting down of the unit by tripping the high temperature cutout.
8. **This heater is equipped with two bimetal thermal high-limit cutouts**, one automatic reset type and one manual reset type. The heater is not to be operated with the high-limit cutouts disabled or disconnected from the control circuit.
9. Keep all electrical enclosure covers tightly closed and secured with all bolts and threads. Cover joints must be clean before replacing covers. Keep away from rain or snow. Heater is for dry indoor use only.
10. All unused threaded openings not used for supply wiring or remote mount room thermostat must be fitted with threaded plugs approved for use in hazardous locations.
11. The heat exchanger is a factory vacuum-sealed unit. Do not attempt to loosen or tighten the vacuum plug or pressure relief device. A loss of vacuum could cause nuisance tripping of the thermal cutouts or high pressures which will cause the relief device to actuate with an accompanying loss of fluid.
12. The heat exchanger is filled with a mixture of water and inhibited **ethylene glycol** which is **poisonous**. Contact with the fluid at operating temperatures may produce a burn hazard. Suggested first aid consists of flushing eyes with plenty of water and to wash off skin in flowing water or shower. If any fluid leakage occurs from the heater, disconnect it from the power supply and have the heat exchanger replaced with a factory supplied unit.
13. Heater must be kept clean. When operating in a dirty environment, regularly clean the fin tubes, fan, and fan guard. Refer to recommended maintenance procedures.
14. Do not operate heater in atmospheres which are corrosive to aluminum or steel.
15. See applicable electrical codes for seal requirements in field installed conduits. Factory installed conduits require no further sealing.
16. **Crackling or pinging noises within the heat exchanger during start up may occur. This is normal.**
17. Air discharge at the bottom of the heater may be warmer than at the top. This is normal.
18. Do not attempt to install a Remote Fan Only Switch. **Do not modify the heater in any way.**
19. Use factory approved replacement parts only. Contact factory for any questions or concerns.

**Enclosure Entries**

| Entry | Entry Type         | Entry Detail                     |
|-------|--------------------|----------------------------------|
| A     | Threaded: 1" NPT   | Main power                       |
| B     | Threaded: 3/4" NPT | Accessories                      |
| C     | Threaded: 3/4" NPT | System wires (conduit)           |
| D     | Threaded: 1/2" NPT | Accessories                      |
| E     | Threaded: 1/2" NPT | Accessories                      |
| F     | Threaded: 3/4" NPT | Element wires (vertical conduit) |

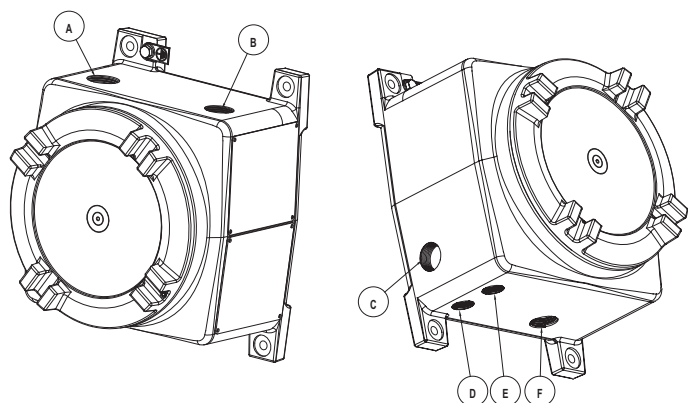



— WARNING! —

Read and follow the instructions in this manual. Failure to do so may result in severe or fatal injury.

— INSTALLATION —  
Mechanical

### Location

Please follow guidelines below for optimum heating results:

1. Do not install heaters such that airflow is blocked or impeded by equipment or walls.
2. For occupant comfort, position heaters so that air discharge is directed across areas of highest heat loss, such as doors, windows, and outside walls.
3. For large areas, arrange heaters such that the air discharge of one heater is directed towards the inlet of the next heater. This sets up a rotational airflow with air circulation in the central area of the building.
4. For equipment freeze protection, direct air discharge at equipment.
5. For large workshops or warehouses it may be acceptable to use fewer, larger heaters.
6. Locate remote mount room thermostat on interior partition walls or posts away from cold drafts, internal heat sources, and away from heater discharge air streams.

### Mounting

1. A variety of mounting brackets are available from the factory to aid in installation.
2. If using mounting hardware or a supporting structure not supplied by the factory, the unit should be suspended through the four 9/16 in. (14 mm) mounting holes on top of the unit with Grade 5, 1/2 in. UNC bolts. Lock washers should be used on all mounting nuts and bolts to ensure they don't vibrate or work loose due to fan vibration or other vibration transmitted to the heater. If in doubt consult factory.
3. It is essential that adequate structural support be provided for installation. **The mounting structure must be strong enough to support the heaters weight**, provide sufficient stiffness to prevent excessive vibration, and withstand all probable abusive situations such as transportable installations where truck off-loading impacts, etc. may occur. Refer to table on Page 3, XEU1 Specifications by Model Size, for heater net weights.

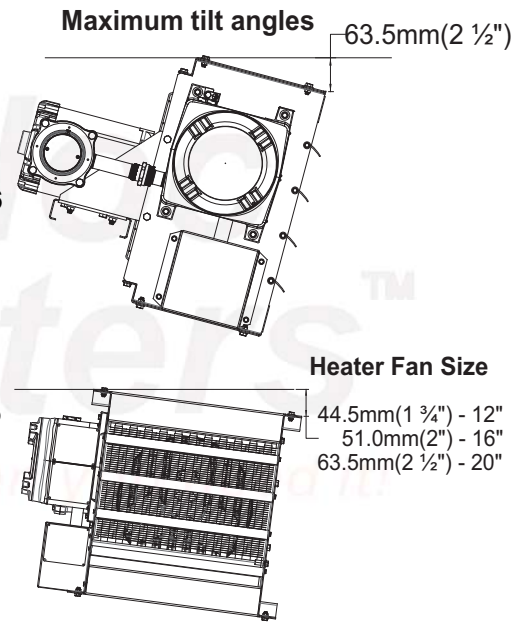

### Mounting Heights and Clearances

1. To ensure that warm air reaches the floor observe the recommended maximum mounting heights in table on Page 3, XEU1 Specifications by Model Size. Heaters may be mounted at higher elevations and still provide warm air at floor level however, the maximum mounting elevation at which this occurs depends on location and operational conditions.
2. Louvers may be adjusted to provide greater downward deflection of the discharge air. However, louvers must not be set less than 30 degrees of the closed position.

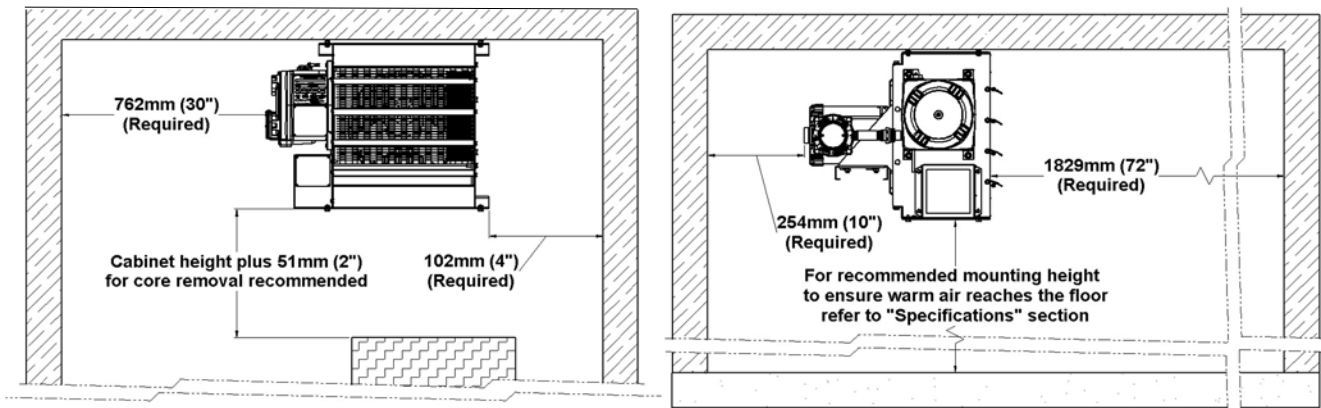

**— WARNING! —**

**Read and follow the instructions in this manual. Failure to do so may result in severe or fatal injury.**

**— INSTALLATION —  
Electrical**

1. Heater is to be connected and serviced only by qualified electrician experienced with hazardous location equipment. It is the responsibility of the installer to verify the safety and suitability of the installation.
2. **Explosion/Electric Shock Hazard.** Disconnect heater from power supply or fuse box before opening enclosures or servicing heater. Lock the switch in the "OFF" (open) position and/or tag the switch to prevent unexpected power application.
3. Use copper conductors only for supply wires and approved explosion-proof means of wiring during installation. Use minimum 90°C rated wire. Refer to "Supply Wire Requirements" table and heater data plate for conductor wire rating.

4. Installation must include appropriate over-current protection devices (fusing or circuit breakers) as required by the CEC or NEC. Refer to "Supply Wire Requirements" table and heater data plate for current ratings. Supply voltage is to be within 10% of the data plate voltage.

**XEU1 Supply Wire Requirements**

| Model               | kW  | Volts | Ø | Total Current Amps | Minimum Circuit Ampacity | Max Fuse Amps | Supply Wire (AWG) |
|---------------------|-----|-------|---|--------------------|--------------------------|---------------|-------------------|
| XEU1-12-030-208160- | 3   | 208   | 1 | 16.7               | 20.9                     | 25            | 10                |
| XEU1-12-030-240160- | 3   | 240   | 1 | 14.9               | 18.6                     | 20            | 12                |
| XEU1-12-030-208360- | 3   | 208   | 3 | 9.4                | 11.8                     | 15            | 14                |
| XEU1-12-030-240360- | 3   | 240   | 3 | 8.3                | 10.4                     | 15            | 14                |
| XEU1-12-030-480360- | 3   | 480   | 3 | 4.2                | 5.2                      | 15            | 14                |
| XEU1-12-030-600360- | 3   | 600   | 3 | 3.3                | 4.1                      | 15            | 14                |
| XEU1-12-050-208160- | 5   | 208   | 1 | 26.3               | 32.9                     | 35            | 8                 |
| XEU1-12-050-240160- | 5   | 240   | 1 | 23.2               | 29.0                     | 30            | 10                |
| XEU1-12-050-208360- | 5   | 208   | 3 | 15.0               | 18.7                     | 20            | 12                |
| XEU1-12-050-240360- | 5   | 240   | 3 | 13.1               | 16.4                     | 20            | 12                |
| XEU1-12-050-480360- | 5   | 480   | 3 | 6.6                | 8.2                      | 15            | 14                |
| XEU1-12-050-600360- | 5   | 600   | 3 | 5.2                | 6.6                      | 15            | 14                |
| XEU1-12-075-208160- | 7.5 | 208   | 1 | 38.4               | 47.9                     | 50            | 8                 |
| XEU1-12-075-240160- | 7.5 | 240   | 1 | 33.7               | 42.1                     | 45            | 8                 |
| XEU1-12-075-208360- | 7.5 | 208   | 3 | 21.9               | 27.4                     | 30            | 10                |
| XEU1-12-075-240360- | 7.5 | 240   | 3 | 19.1               | 23.9                     | 25            | 10                |
| XEU1-12-075-480360- | 7.5 | 480   | 3 | 9.6                | 12.0                     | 15            | 14                |
| XEU1-12-075-600360- | 7.5 | 600   | 3 | 7.6                | 9.6                      | 15            | 14                |
| XEU1-12-100-240160- | 10  | 240   | 1 | 44.1               | 55.1                     | 60            | 6                 |
| XEU1-12-100-208360- | 10  | 208   | 3 | 28.9               | 36.1                     | 40            | 8                 |
| XEU1-12-100-240360- | 10  | 240   | 3 | 25.2               | 31.4                     | 35            | 8                 |
| XEU1-12-100-480360- | 10  | 480   | 3 | 12.6               | 15.7                     | 20            | 12                |
| XEU1-12-100-600360- | 10  | 600   | 3 | 10.1               | 12.6                     | 15            | 14                |
| XEU1-16-150-208360- | 15  | 208   | 3 | 42.7               | 53.4                     | 60            | 6                 |
| XEU1-16-150-240360- | 15  | 240   | 3 | 37.2               | 46.5                     | 50            | 8                 |
| XEU1-16-150-480360- | 15  | 480   | 3 | 18.6               | 23.2                     | 25            | 10                |
| XEU1-16-150-600360- | 15  | 600   | 3 | 14.9               | 18.6                     | 20            | 12                |
| XEU1-16-200-480360- | 20  | 480   | 3 | 24.6               | 30.8                     | 35            | 8                 |
| XEU1-16-200-600360- | 20  | 600   | 3 | 19.7               | 24.6                     | 25            | 10                |
| XEU1-20-250-480360- | 25  | 480   | 3 | 31.3               | 39.1                     | 40            | 8                 |
| XEU1-20-250-600360- | 25  | 600   | 3 | 25.1               | 31.3                     | 35            | 8                 |
| XEU1-20-300-480360- | 30  | 480   | 3 | 37.3               | 46.6                     | 50            | 8                 |
| XEU1-20-300-600360- | 30  | 600   | 3 | 29.9               | 37.3                     | 40            | 8                 |
| XEU1-20-350-480360- | 35  | 480   | 3 | 43.3               | 54.1                     | 60            | 6                 |
| XEU1-20-350-600360- | 35  | 600   | 3 | 34.7               | 43.3                     | 45            | 8                 |

5. Confirm that the electrical power supply matches the nameplate voltage, phase, amperage and frequency rating of the heater to be connected.

6. Supply conductors and ground conductor pass through the 1 in. NPT rigid conduit opening on the control enclosure.

7. Proper installation of the heater requires that an adequate grounding conductor be connected to the ground terminal. This terminal is made of copper and is located on the top right-hand corner of the printed circuit board within the control enclosure.

8. Heater may be supplied with a factory installed integral room thermostat with lockable temperature dial (See Figure 1). If a **remote explosion-proof room thermostat** is used, connection is to be made via the 3/4" NPT entry (entry "B" listed in the "Enclosure Entries" table on page 4). Refer to the thermostat installation manual and the wiring diagrams on page 9 to connect the remote thermostat.

9. Refer to wiring diagram on Page 9 to ensure that all connections are as required and securely fastened.

10. For heaters supplied with a factory installed integral disconnect switch (See Figure 1), field wiring is as follows:
  - a. Remove the Disconnect cover assembly from the base by removing the six (6) cover bolts. Set the cover assembly aside. CAUTION: Damaging the mating surfaces of the enclosure could destroy the flame path and jeopardize the integrity of the flame proof enclosure.
  - b. Supply conductors and ground conductor pass through the 1 in. NPT rigid conduit opening located on the top or bottom of Disconnect Enclosure. Supply conductors to be wired to DIN rail mounted Disconnect Switch inside. Ground conductor to be wired to Ground Lug fastened to inside of Disconnect Enclosure. Refer to wiring diagram on Page 9.
  - c. Attach cover to the enclosure using the six (6) bolts. **Tighten to 150 inch-pounds ± 5 in-lbs.**

11. **All** unused threaded openings in enclosures, not used for supply wiring or external room thermostat, must be fitted with threaded plugs approved for use in hazardous locations (included). Factory installed conduits require no additional sealing.

12. Installer must seal each conduit run within 18" (457 mm) of enclosure. This seal must be suitable and listed for hazardous locations. Ensure that any liquids used in the sealing process do not enter into any of the electrical enclosures.

13. Ensure that input conductors and conduit have adequate strain relief at installation.

14. Before application of electrical power, recheck all connections to ensure compliance with the wiring diagram and any code requirements. Remove any foreign objects from the control box and heater. Ensure all wire terminals are tight and not pinching the wire insulation. Reinstall cover tightly.

15. **On all three-phase heaters, it is necessary to verify that the fan rotation is correct** (counter clockwise when facing the rear of the heater). If air delivery is not from the front of the heater, reverse any two supply leads at the main power contactor located in the control enclosure.

16. The explosion-proof control enclosure and element enclosures are designed with O-rings, threaded joints and metal-to-metal contact at the lid or cover joint to prevent an explosion. Do not attempt to install gasket material of any type at these joints. A light coating of anti-seize compound may be applied to the threads to prevent seizing.



Figure 1

— WARNING! —

Heater is to be serviced only by qualified electrician experienced with hazardous location equipment.

**Explosion/Electric Shock Hazard.** Disconnect heater from power supply or fuse box before opening enclosures or servicing heater. Lock the switch in the "OFF" (open) position and/or tag the switch to prevent unexpected power application.

— Repair and Replacement —

**Heat Exchanger Replacement** (See Page 10 for assembly diagram)

The heat exchanger core assembly has been fluid filled and vacuum sealed at the factory and is not field repairable. Replacement heat exchanger core assemblies are available from the factory and are inspected and electrically tested for correct heat output and proper operation of the high-limits.

1. **Explosion/Electric Shock Hazard.** Disconnect heater from power supply or fuse box before opening enclosures or servicing heater. Lock the switch in the "OFF" (open) position and/or tag the switch to prevent unexpected power application.
2. To prevent burn hazard, be sure heat exchanger and fluid has been allowed to cool before proceeding.
3. Remove cabinet bottom panel, element housing cover, element enclosure cover, & control enclosure cover.
4. From the control enclosure, disconnect two high-limit wires from printed circuit board terminal block marked 3 & 4 and disconnect three output heating element wires from contactor terminals marked T1, T2, & T3.
5. Slightly loosen all cabinet bolts and louver screws to prevent heat exchanger from binding.
6. The heat exchanger is secured by three 1/4 in. bolts on the right-side cabinet panel (when facing front of heater) and one 1/4 in. bolt located on the left side of heater. On 3 - 10 kW models the left-side bolt is located at the top right-hand foot of control enclosure. On 15 - 35 kW models the left-side bolt is located above the control enclosure. With an assistant supporting the weight of the heat exchanger remove these 4 bolts. Carefully lower the heat exchanger from the cabinet.
7. Remove the old blue compound from the existing vertical conduit (take care not to damage the conduit surface). Apply the new blue compound to the conduit where it mates with the core housing.
8. Install the new heat exchanger core by reversing the procedure in steps 1 - 6.

**Temperature High-Limit Replacement** (See Page 10 for assembly diagram)

This heat-exchanger includes one automatic reset & one manual reset temperature high-limit that are wired in series. The automatic reset high-limit is rated for 100,000 cycles and is for a temporary failure condition. Continuous nuisance tripping of the automatic reset is generally not the fault of the high-limit but is usually caused by incorrect operating voltage, blocked air inlet or outlet, fan/motor malfunction, high ambient temperatures, excessively dirty heat exchanger or leaking heat exchanger. **Care should be taken to determine the exact reason that the automatic reset high-limit control tripped so the problem can be resolved immediately.** The automatic reset high-limit normally fails in the open position, however, it can also fail closed.

If the automatic reset fails in the open position the heater will not function and the high-limit should be replaced. **The occurrence of the manual reset high-limit control to trip is an abnormal condition and indicates that the automatic reset high-limit has failed in the closed position. If this occurs remove the heater from service immediately and replace both the automatic and manual reset high-limits. Determine the exact reason that the automatic reset high-limit control tripped so the problem can be resolved immediately.** If the manual reset high-limit shuts down the heater it will have to be reset by pressing on the small reset button protruding from the center of the high-limit device.

1. De-energize the heater electrical supply circuit.
2. Remove element housing cover, and element enclosure cover.
3. Remove the wires from both the auto and manual high limits, make note of the wire position and connection points.
4. Remove automatic reset high-limit assembly by unscrewing (counter-clockwise), clean the inside of the thermowell. A clean thermowell ensures good thermal contact. Needle nose pliers are recommended for this step.
5. Remove manual reset high-limit assembly by removing the two retaining screws, clean any residual heat sink compound from the housing surface. A clean housing surface ensures good thermal contact
6. Replace both the auto and manual high-limits with factory supplied units only. Apply heat sink compound to the bottom of the auto high-limit, and screw into thermowell. Apply heat sink compound to the bottom of the manual high-limit and attach to the housing using the two screws.
7. Re-attach the wires to both high limits.
8. Replace element housing cover, and element enclosure cover.
9. Energize the heater electrical supply circuit and let run for 15 minutes to reach a stable operating temperature.
10. If heater operation appears to be normal, place unit into service.

**— WARNING! —**

Heater is to be serviced only by qualified electrician experienced with hazardous location equipment.

**Explosion/Electric Shock Hazard.** Disconnect heater from power supply or fuse box before opening enclosures or servicing heater. Lock the switch in the "OFF" (open) position and/or tag the switch to prevent unexpected power application.

**— Repair and Replacement, Continued —**

**Fan, Fan Guard or Motor Replacement** (See Page 10 for assembly diagram)

**The motor is a sealed unit that requires no lubrication. If the motor is defective, it must be replaced with an original factory supplied motor.**

1. Remove four bolts holding motor to the motor mount, and covers from junction box and control enclosure. On units with an integral room thermostat, remove 4 bolts on front face of thermostat enclosure .
2. Detach and remove two-piece fan guard assembly by removing top and bottom screws that attach the fan guard to the cabinet.
3. Loosen fan blade set screw and remove fan blade from end of motor shaft leaving it in fan panel opening.
4. Unscrew the expansion union fitting between motor and motor enclosure (or integral thermostat enclosure).
5. **If replacing motor**, note wire connections for future reference and cut all wires leading to the motor close to the terminations. All motor wires are permanently marked according to the nameplate on the motor. Lift the motor assembly off the motor mount.
6. **If replacing fan blade only** do not cut any wires and move the motor assembly back sufficient to assist fan blade removal.
7. To reassemble, place fan blade inside fan panel opening and then place motor onto motor mount. Slip fan blade onto motor shaft and ensure fan hub is flush with end of motor shaft. Tighten set screw to 150 in-lbs torque.
8. Fasten the two-piece fan guards to the cabinet.
9. Tighten conduit fittings between motor and motor enclosure (or integral thermostat enclosure). Center fan in fan-panel opening and leave approximately 1/16" to 3/16" (1.6 to 4.8 mm) gap between motor face and fan guard.
10. Bolt motor to motor mount, tighten nuts to 250 in-lbs torque. Manually spin the fan blade to ensure it rotates freely before reconnecting heater to power supply. Fan must rotate counterclockwise when viewed from rear of heater.

| Torque Settings                            |                 |
|--------------------------------------------|-----------------|
| Item                                       | Torque (in-lbs) |
| Fan blade set screw (1 only)               | 150             |
| 5/16 - 18 UNC motor nuts                   | 250             |
| 5/16 - 18 UNC motor mount bolts            | 250             |
| 1/4 - 20 UNC fan panel bolts               | 100             |
| 1/4 - 20 UNC fan guard self tapping screws | 100             |
| #10 - 24 UNC louver blade screws           | 28              |

**Contactors** (See Page 10 for assembly diagram)

1. Loosen, but do not remove contactor mounting screws. Slide contactor off mounting screws.
2. Replace with a factory supplied contactor of the same rating.

**Transformer** (See Page 10 for assembly diagram)

1. Replace with a factory supplied transformer of the same rating.
2. On the new transformer, select primary wires to match heater voltage. Ensure that the correct transformer secondary lead is grounded (see Page 9 wiring diagram). Individually terminate all unused wires using closed end connections.

**Printed Circuit Board** (See Page 10 for assembly diagram)

1. Replace with a factory supplied printed circuit board (see Page 9 wiring diagram).

**Thermal Delay Fuse** (See Page 10 for assembly diagram)

1. Replace fuse with one of the same type and rating as indicated on printed circuit board or refer to parts list. An extra fuse should be stored in the clips marked "SPARE".



**— Warning —**

Wiring should only be connected by qualified personnel experienced in electrical work.

**— Electrical Wiring —**

**Wiring Diagram for Standard Fan Operation**

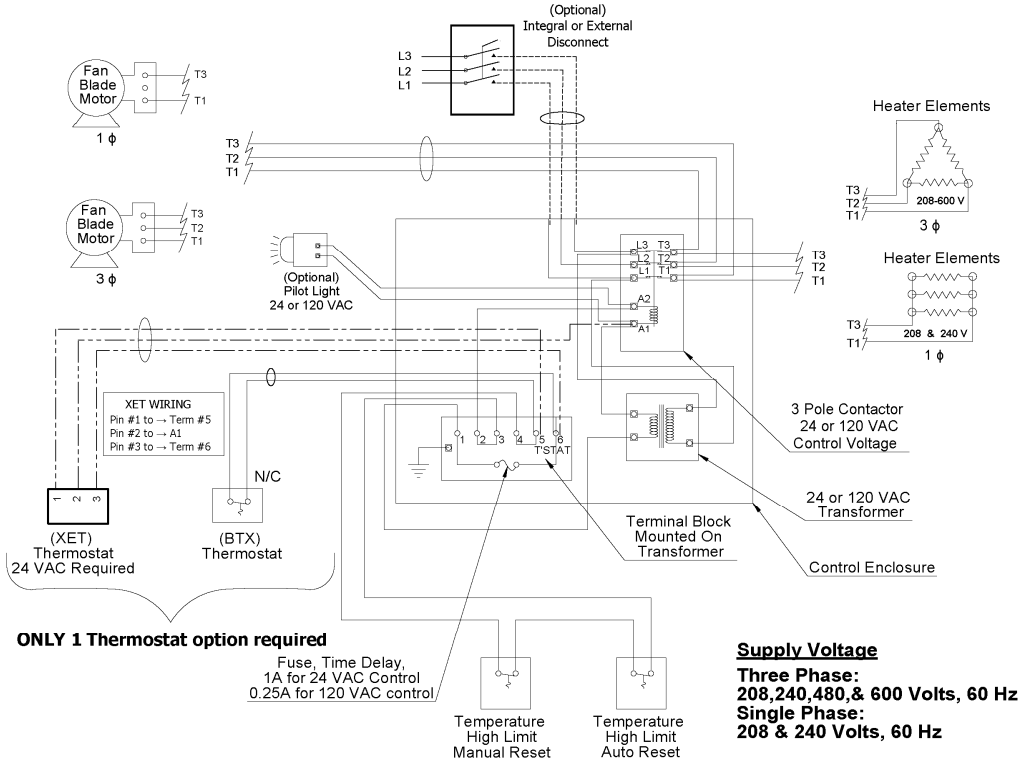

**Wiring Diagram for Continuous Fan Operation**

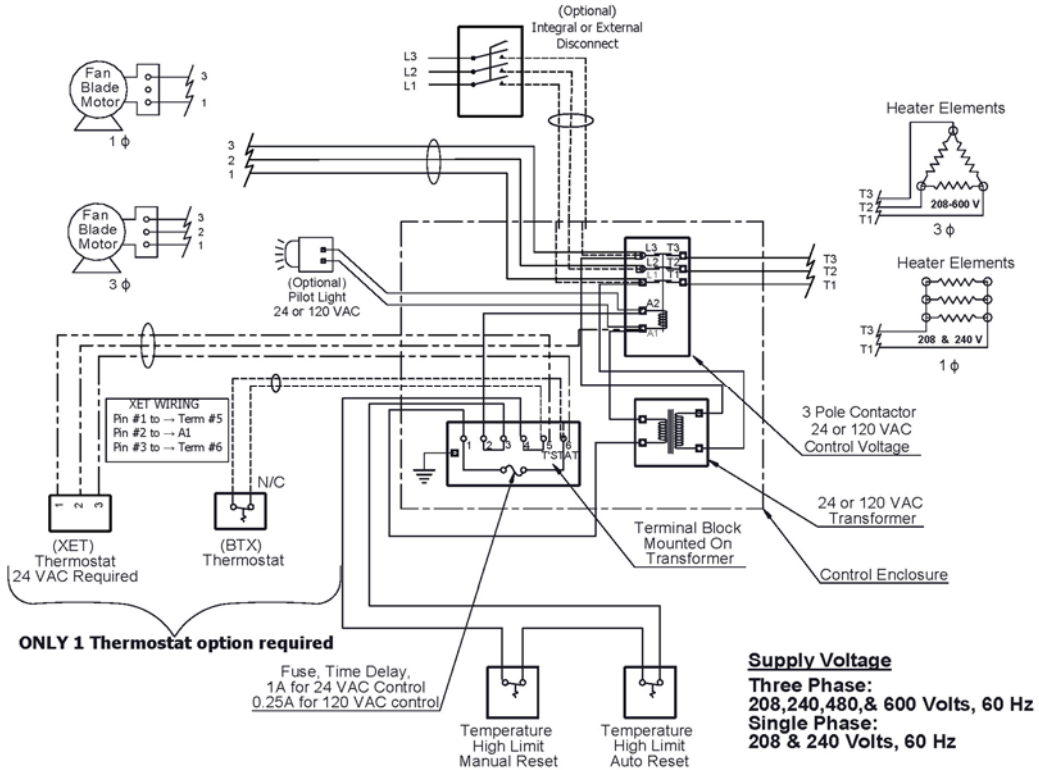

— Assembly Diagram —

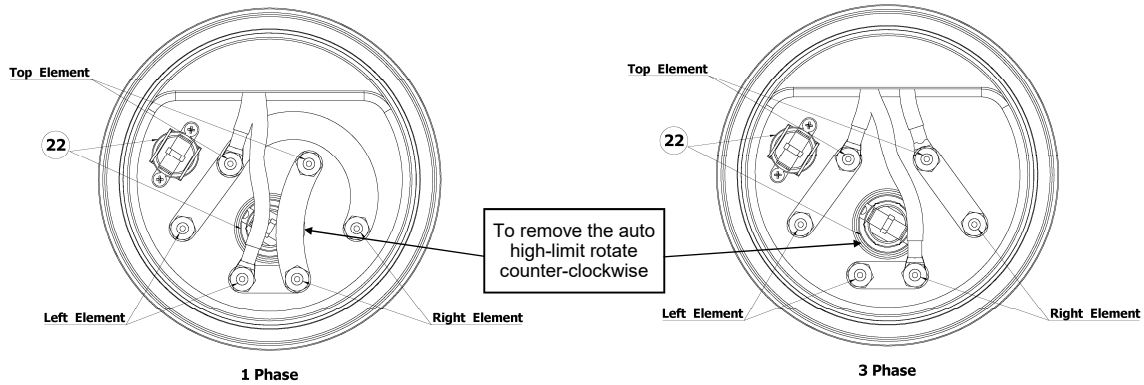
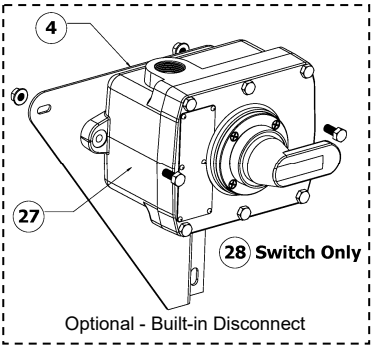
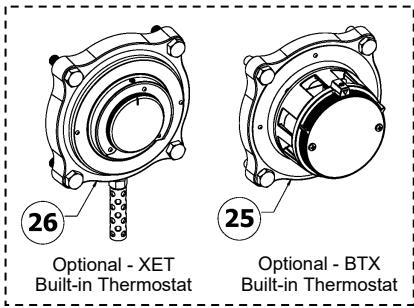
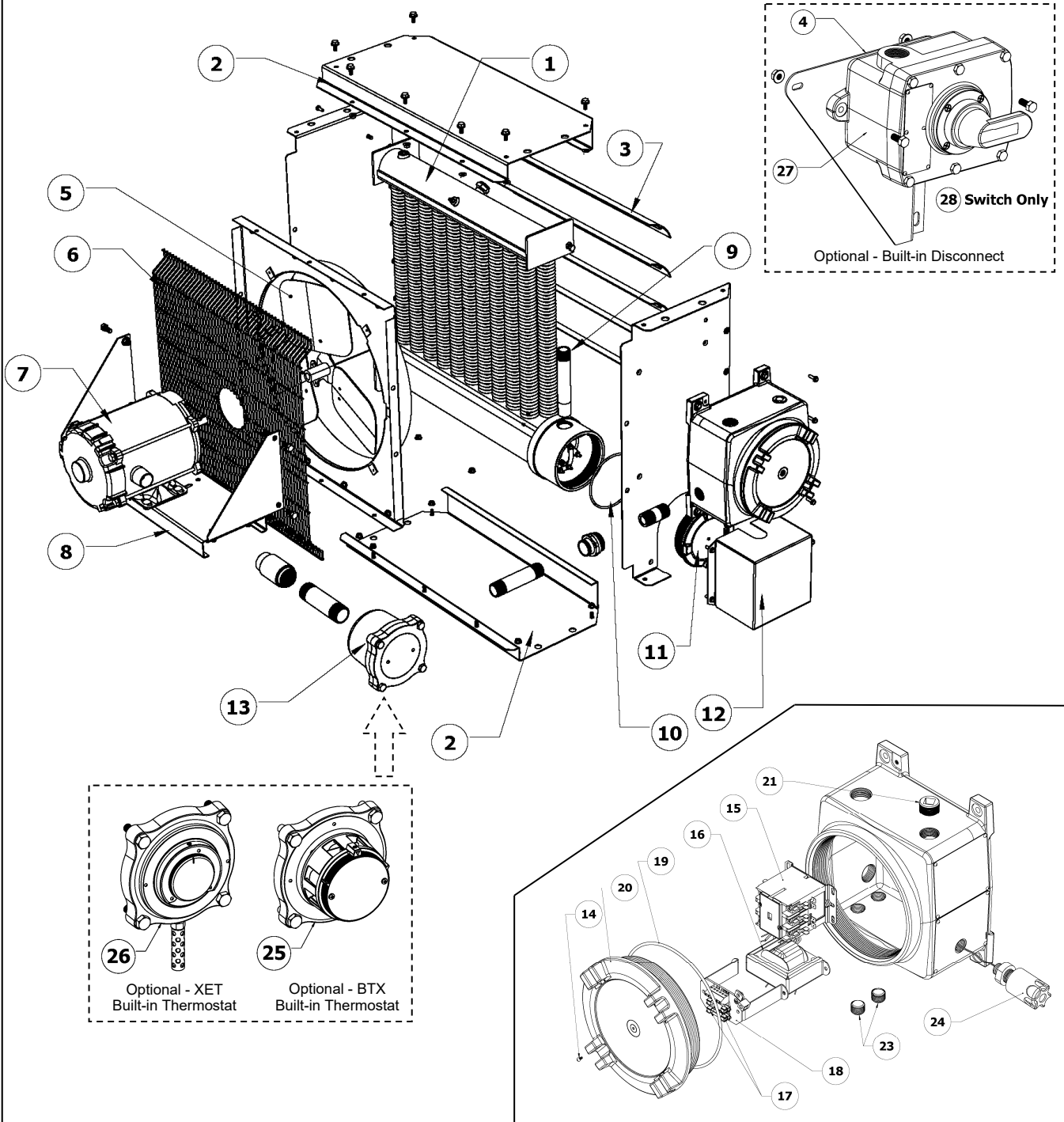

**— Parts List —**

**\*\*\* Please have model & serial number available before calling \*\*\***

| Item No. | Description                                                | 12" Fan Size                                                                            |                | 16" Fan Size                     | 20" Fan Size                                           |
|----------|------------------------------------------------------------|-----------------------------------------------------------------------------------------|----------------|----------------------------------|--------------------------------------------------------|
|          |                                                            | 3, 5 & 7.5 kW                                                                           | 10 kW          | 15 & 20 kW                       | 25, 30 & 35 kW                                         |
| 1        | Core Assembly (with bus bars)                              | Specify Voltage, Phase, and Kilowatts ( V-Ph-kW)                                        |                |                                  |                                                        |
| 2        | Panel, Top or Bottom                                       | 1048                                                                                    |                | 1049                             | 1050                                                   |
| 3        | Louver Blade Kit                                           | 1625                                                                                    |                | 1626                             | 1627                                                   |
| 4        | Bracket, Disconnect Switch, Left                           | 1456                                                                                    |                |                                  |                                                        |
| 5        | Fan Blade                                                  | 3.0 kW = 1544<br>5.0 kW = 1545<br>7.5 kW = 1546                                         | 10.0 kW = 1547 | 15.0 kW = 1548<br>20.0 kW = 1549 | 25.0 kW = 1550<br>30.0 & 35.0 kW = 1551                |
| 6        | Fan Guard Kit                                              | 1157                                                                                    |                | 1158                             | 1159                                                   |
| 7        | Motor, Explosion-proof                                     | 115/208-230V, 1Ø, 60Hz = G639<br>208-230/460V, 3Ø, 60Hz = G646<br>575V, 3Ø, 60Hz = G664 |                |                                  | 208-230/460V, 3Ø, 60Hz = G649<br>575V, 3Ø, 60Hz = G666 |
| 8        | Motor Mount Kit                                            | 1151                                                                                    |                | 1152                             | 1153                                                   |
| 9        | Vertical Conduit Kit                                       | 1072                                                                                    |                | 1073                             | 1074                                                   |
| 10       | O-ring, Element Enclosure Cover                            | 1080                                                                                    |                |                                  |                                                        |
| 11       | Element Enclosure Cover Kit (includes o-ring, item #10)    | 1081                                                                                    |                |                                  |                                                        |
| 12       | Guard, Element Enclosure                                   | 1082                                                                                    |                |                                  |                                                        |
| 13       | Junction Box, BLK1, Built-in                               | BLK1-C-N-A                                                                              |                |                                  |                                                        |
| 14       | Set Screw, Control Enclosure                               | 1083                                                                                    |                |                                  |                                                        |
| 15       | Contactor                                                  | 120V = 2001,                                                                            |                | 24V = 2000                       |                                                        |
| 16       | Transformer                                                | 120V = 1555,                                                                            |                | 24V = 1554                       |                                                        |
| 17       | Fuse, Time Delay                                           | 120V = 1/4 Amp (1556),                                                                  |                | 24V = 1 Amp (1087)               |                                                        |
| 18       | Printed Circuit Board Assembly (includes #17, 2 pieces)    | 120V = 1307,                                                                            |                | 24V = 1086                       |                                                        |
| 19       | O-ring, Control Enclosure Cover                            | 1942                                                                                    |                |                                  |                                                        |
| 20       | Control Enclosure Cover Kit (includes #14 and #19)         | 1089                                                                                    |                |                                  |                                                        |
| 21       | Plug, 3/4" NPT Explosion-proof                             | 1841                                                                                    |                |                                  |                                                        |
| 22       | High Limit Kit (includes both auto and manual high limits) | 1102                                                                                    |                |                                  |                                                        |
| 23       | Plug, 1/2" NPT Explosion-proof                             | 2619                                                                                    |                |                                  |                                                        |
| 24       | Light, Pilot (Green LED)                                   | 120V = 1558,                                                                            |                | 24V = 1557                       |                                                        |
| 25       | Thermostat, BTX, Built-in                                  | BTX2-15A-C-N-A - For Use With 120VAC or 24VAC Control Voltage                           |                |                                  |                                                        |
| 26       | Thermostat, XET, Built-in                                  | XET1-1-C-N-A - For Use With 24VAC Control Voltage Only                                  |                |                                  |                                                        |
| 27       | Disconnect, XDC-01, 600V, 50 Amp                           | XDC-01                                                                                  |                |                                  |                                                        |
| 28       | Switch, 600V, 50 Amp (for XDC-01)                          | 1583                                                                                    |                |                                  |                                                        |

— WARNING! —

Heater should only be service by qualified personnel experienced in electrical work.

Disconnect unit heater from power supply before starting any service or repair work. Lock the disconnect switch in the "OFF" (open) position and/or tag the switch to prevent unexpected power application. Failure to follow these procedures may result in severe or fatal injury.

— Maintenance Program —

**Regular inspection, based on a schedule determined by the amount of dirt in the atmosphere, assures maximum operating economy and heating capacity.**

**Annual Inspection** (before each heating season)

1. Check all terminal connections and electrical conductors for damage, looseness, defects, fraying, etc. and replace or tighten where applicable.
2. Inspect contactor contacts. If badly pitted, burned or welded shut, replace with factory supplied contactor. It is recommended that the contactor be replaced every two (2) years.
3. Inspect thermal delay fuses. Fuse rating and type are printed on circuit board. Correct fuse must be in the "ACTIVE" fuse clip. An extra fuse should be stored in the clips marked "SPARE".
4. Check for fluid leakage from heat-exchanger. The heat exchanger is filled with a mixture of water and inhibited **ethylene glycol, which is poisonous**, and is factory vacuum-sealed. If fluid leakage occurs, remove heater from service and have the heat-exchanger replaced by a factory replacement unit. Refer to "Repair and Replacement" section for complete details. Do not attempt to loosen or tighten the vacuum plug or pressure relief device. A loss of vacuum could cause nuisance tripping of the thermal cutouts or high pressures which will cause the relief device to actuate with an accompanying loss of fluid.
5. Check all explosion-proof conduit and fittings. Replace damaged components. All threaded conduit connections must have a minimum 5 turns of engagement. Taper threaded connections must be at least hand tight. Inside of enclosures must be clean, dry, and free from any foreign materials. Enclosure covers must also be completely on and tight.
6. Check electrical resistance on all load side legs. Reading should be balanced ( $\pm 5\%$ ).
7. Check motor shaft bearing play. Replace motor if play is excessive or if motor does not run quietly and smoothly. Motor bearings are permanently lubricated.
8. Check fan blade. Replace immediately if cracked or damaged.
9. Check louvers. Louver screws should be tight. Louvers must not be set less than 30 degrees of the closed position.
10. Check the tightness of all hardware. All nuts and bolts, including mounting hardware, must be tightened to correct torque settings on Page 8.
11. Turn heater motor on for a minimum of 10 minutes. Crackling or pinging noises within the heater during start up may occur. This is normal. Check for air exiting heater through louvers and smooth running of motor.

**Periodic Maintenance** (before and as required during heating season)

1. Clean the following (remove dust using compressed air):
  - Finned tubes
  - Fan
  - Fan Guard
  - Motor
  - Louvers

⇒ Wipe cabinet with a damp cloth to remove any remaining dirt / dust and to mitigate any electrostatic charge buildup
2. Check the following:
  - Motor for smooth and quiet operation
  - Louvers for proper angle and tightness
  - All explosion-proof covers and fittings for tightness
  - Contactor for signs of wear or pitting
  - Drain in control enclosure is free of blockage (if installed)







NOTES



*Hazloc  
Heaters™*

*Safe heat when you need it!*

NOTES



*Hazloc  
Heaters™*

*Safe heat when you need it!*

## Limited 36-Month Warranty

**Hazloc Heaters™** warrants all **XEU1** series of explosion-proof electric heaters against defects in materials and workmanship under normal conditions of use for a period of thirty-six (36) months from date of purchase based on the following terms:

1. The heater must not be modified in any way.
2. The heater must be stored, installed and used only in accordance with the owner's manual and attached data plate information.
3. Replacement parts will be provided free of charge as necessary to restore any unit to normal operating condition, provided that the defective parts be returned to us freight prepaid and that the replacement parts be accepted freight collect.
4. The complete heater may be returned to our manufacturing plant for repair or replacement (at our discretion), freight charges prepaid.
5. Components damaged by contamination from dirt, dust, etc. or corrosion will not be considered as defects.
6. This warranty shall be limited to the actual equipment involved and, under no circumstances, shall include or extend to installation or removal costs, or to consequential damages or losses.



#1, 666 Goddard Ave. NE  
Calgary, Alberta T2K 5X3  
Canada  
Tel.: +1-403-730-2488  
Fax: +1-403-730-2482  
Customer Toll Free (U.S. & Canada):  
+1-866-701-Heat (4328)  
[www.HazlocHeaters.com](http://www.HazlocHeaters.com)

PRINTED IN CANADA  
©Copyright 2024

The information contained in this manual has been carefully checked and verified for accuracy. Specifications subject to change without notice.

Hazloc Heaters is a trademark of Hazloc Heaters Inc.