



Hazloc Heaters™

Safe heat when you need it!



HUH2

Hydronic Unit Heater

CRN: 0H14933.2C
400 psig (2758 KPa)

Industrial Grade
Heat-Exchanger Unit Heaters

www.HazlocHeaters.com



Hazloc Heaters™ is a manufacturer of industrial-grade unit heaters suitable for hazardous and severe-duty locations.



The **Hydronic Unit Heater (HUH2)** series of heat-exchanger unit heaters were specifically designed to meet the demanding requirements of the oil & gas industry. The operating conditions of this industry require heating equipment that is safe, reliable, dependable, and available when you need it. The rugged design features of the **HUH2** series also makes it ideal for use in other



heavy-duty industries that include pulp & paper, power generation, mining, steel mills, foundries, water and wastewater treatment plants, chemical plants, and hazardous material storage facilities.

Designed for operating pressures up to 400 PSIG (2758 kPa)!

All **Hazloc Heaters™ HUH2** models are **designed to ASME requirements** for applications with **maximum operating pressures up to 400 PSIG (2758 kPa)**. The six sizes of **HUH2** heaters are available in both single-pass and multi-pass configurations providing you with **20 model choices** to meet your specific requirements.

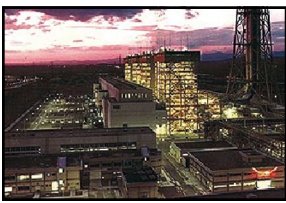

HUH2 heaters are suitable for a wide variety of heating fluids and are **perfect for steam, hot water, or glycol applications**. They are also used with other non-lethal or non-poisonous fluids (as defined by ASME) for both space heating and liquid cooling applications that include but are not limited to hot-oil heaters, lube-oil coolers, product process coolers, pump-seal coolers, etc.

Rugged design, but easily maintained and reversible!

All **HUH2** heaters are designed for industrial applications with all features being heavy-duty to meet your most demanding environments and long-life expectations. Even with heavy-gauge steel construction used throughout the heater it does not inhibit the easy maintenance of the product, since all parts are easily removed. Furthermore, the heater core can be removed without disturbing the heater mounting arrangement or electrical connections. An additional benefit is our reversible core connection feature that allows you to reverse the configuration of the inlet and outlet connection locations, by rotating the core, to suit your installation! (see photo on bottom of page 3)

Interchangeable with other brands of heaters!

Some of **Hazloc Heaters™ HUH2** series are designed with cabinet dimensions and mounting holes equivalent to a major competitor's heaters making them easily interchangeable. Furthermore, our rugged and superior **HUH2** replacement cores are also designed to slide into equivalent sizes of their heaters. An added benefit is our 18-month heater warranty!

Maximum durability... rugged fin tubes and headers!

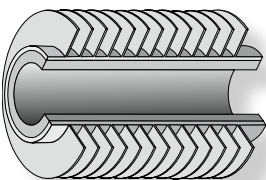

All **HUH2** heat-exchanger cores are constructed using rugged 16-gauge (0.065 in.) carbon-steel tubes with tension-wound aluminum fins and carbon-steel headers for **maximum durability, resistance to corrosion, and longer life** in your demanding applications.

Take advantage of our proprietary heater sizing and selection program!

Hazloc Heaters™ has developed a web-based heater sizing and selection program that will assist you with estimating your building's heating load and in selecting the right **HUH2** series of heater for your application. **Our software computes performance parameters under a diverse range of operating conditions.** Just visit www.HazlocHeaters.com and select Heater Selection Tool to register.

Hazloc Heaters™ heater selection tool is capable of rating heaters for steam, or for fluids based on either the flow-rate or temperature-drop sizing methods. **Our software is also pre-programmed with the following fluid types for quick and easy analysis.**

Steam

Water

Ethylene Glycol/Water

Diethylene Glycol/Water

Therminol 66

Triethylene Glycol/Water

Dowtherm A

Dowtherm G

Propylene Glycol/Water

and others...

Heater Specifications		For clarification of model code sequence, see product literature at www.hazlocheaters.com	
Model Code: HUH2-20-C-5-115160-E			
Connection Type:	2 inch NPT female		
Exchanger Coating:	High Heat Enamel (Standard)		
Fan Diameter:	20 in. fan diameter		
CRN:	CRN: 014933.2 - steam or fluids (not for use with lethal fluids as defined by ASME, Section VIII, Div. 1, A03, UW-2)		
Passes:	5 pass		
Motor:	115 volts, 1 phase, 60 Hz, 1/2 HP	Explosion Proof Motor, Class I & II, Div. 1 & 2; Group C, D, F, & G Temp Code T3B	
	5/8 in. (15.9 mm) outside diameter - 1/8 gauge, 0.065 in. (1.6 mm) wall thickness - carbon steel tubes with 1-1/2 in. (38.1 mm) outside diameter copper/brass 1 foot tension wound aluminum fins @ 10 per inch.		
	• Epoxy powder-coated carbon steel cabinet	• 2-way anodized aluminum louvers	
	• Maximum operating pressure: 400 psig (2758 kPa)	• Maximum design temperature: 550°F (288°C)	
	• Easy-off fan blade replacement feature	• Limited 18 month warranty	
	• Mounting Brackets: None	• Accessories: None	
Input / Output Data			
Heat Output:	135,388.00 BTU/hr		
Quantity Required:	1		
Fluid Type:	60% Ethylene Glycol		
Flow Rate:	8.22 USGPM		
Inlet Fluid Temp:	240.0 °F	Outlet Fluid Temp:	200.0 °F
EAT:	40.0 °F	FAT:	77.7 °F
Operating Pressure (Gauge):	50.00 PSI	Pressure Drop:	1.04 PSI
Altitude:	1000 ft ASL		

Once you know your heating load, all you require is the following input data!

- Type of fluid used
- Operating pressure
- Inlet fluid temperature (liquid applications only)
- Outlet fluid temperature, or available fluid flow rate
- Altitude above sea level (ASL)
- Entering air temperature

If your fluid isn't listed in our program, we can still help!

You can still size our heaters using other fluids not listed above by **manually inputting the following fluid physical properties: Temperature, Density, Specific Heat, Thermal Conductivity, and Viscosity** at two reference points.

This brochure was produced using Imperial units of measure. If required we can provide you with data in Metric units.



Hazloc Heaters™

"Safe heat when you need it!"

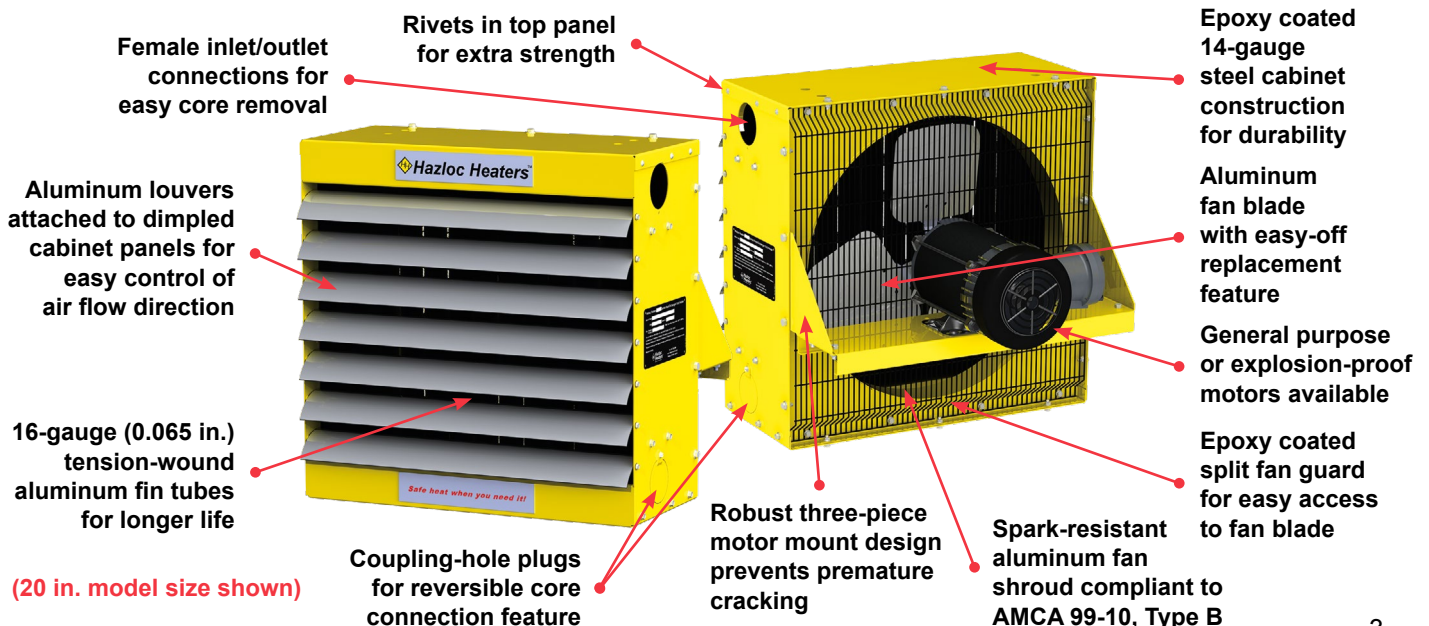

HUH2 Model Coding



Heater Model Code & Option Codes

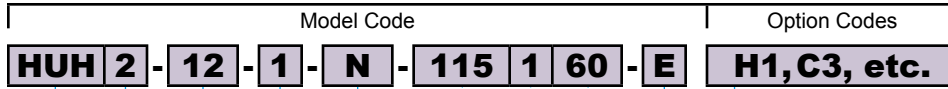

Model Series
HUH

Generation
For major revisions

Fan Size	
12 inches	12
16 inches	16
20 inches	20
24 inches	24
30 inches	30
36 inches	36

Tube Passes	
1 Pass	1
3 Pass	3
5 Pass	5
7 Pass	7

Steam units are **1 pass only**
 Not available on 12" fan size
 Not available on 12", 16", & 20" fan sizes

Approval Type	
North American (GRN)	N

Includes louvers and fan blade
 Includes louvers and fan blade

Options	
H1 ^Δ	Heresite coated core
H2 ^Δ	Heresite coated cabinet
H3 ^Δ	Heresite coated core & cabinet
C2 [◇]	Connection, 2" MNPT SCH. 80 fitting
C3 [◇]	Connection, 2" FNPT CL300# RF flange
ZZ	Special build (Factory assigned code)

Motor Type	
G	General purpose
E [†]	Hazardous location

Motor [‡]		
Voltage	Phase	Frequency
115	1	60
208	1	60
230	1	60
208	3	60
230	3	60
460	3	60
575	3	60

- Δ Contact factory for extended shipping lead times on Heresite coatings.
- ◇ Thread-on fittings. Shipped loose and must be installed on site. C3 connection also includes C2 connection.
- † Standard Marathon NEMA ex-proof motor is suitable for Class I & II, Div. 1 & 2, Groups C, D, F & G; T3B; Maximum ambient air temp of 40°C.
- * Other voltages / frequencies available upon request. Longer lead times may apply. Contact factory.
- ‡ NEMA motors are to be operated at ±10% of the nameplate voltage. If the motor is marked 208-230V the tolerance must be calculated from 230V. If the motor is marked 230V it is still suitable for 208V operation but the tolerance must be calculated from 230V. For 3-phase motors the line-to-line full load voltage must be balanced within 1%.

HUH2 Physical Dimensions (12 inch to 30 inch models)

Note: Inlet and outlet coupling connection locations can be reversed in the field by rotating the core.

Fan Size	12	16	20	24	30
Dim.	Inches (mm)	Inches (mm)	Inches (mm)	Inches (mm)	Inches (mm)
A	12.60 (320)	15.51 (394)	19.49 (495)	23.46 (596)	29.53 (750)
B	4.02 (102)	4.02 (102)	4.02 (102)	4.65 (118)	5.71 (145)
C	1.85 (47)	2.38 (60.5)	2.40 (61)	2.40 (61)	2.40 (61)
D	16.30 (414)	20.28 (515)	24.29 (617)	28.27 (718)	34.33 (872)
E	9.76 (248)	9.76 (248)	10.51 (267)	11.81 (300)	13.78 (350)
F	6.77 (172)	5.77 (146.5)	5.75 (146)	6.69 (170)	7.48 (190)
G	(2 holes)	1.75 (44.5)	2.50 (63.5)	2.76 (70)	3.15 (80)
H	2.64 (67)	2.64 (67)	3.62 (92)	4.29 (109)	4.37 (111)
I	19.07 (484)	21.98 (558)	25.96 (659)	29.93 (760)	36.00 (914)
J	11.02 (280)	15.00 (381)	17.00 (432)	19.69 (500)	25.59 (650)
K	1.38 (35)	1.38 (35)	1.38 (35)	1.38 (35)	1.38 (35)
L	19.86 (504)	19.86 (504)	22.57 (573)	23.90 (607)	26.37 (670)
M	22.49 (571)	26.47 (672)	30.48 (774)	34.46 (875)	40.5 (1029)

Dedicated to Performance and Reliability!

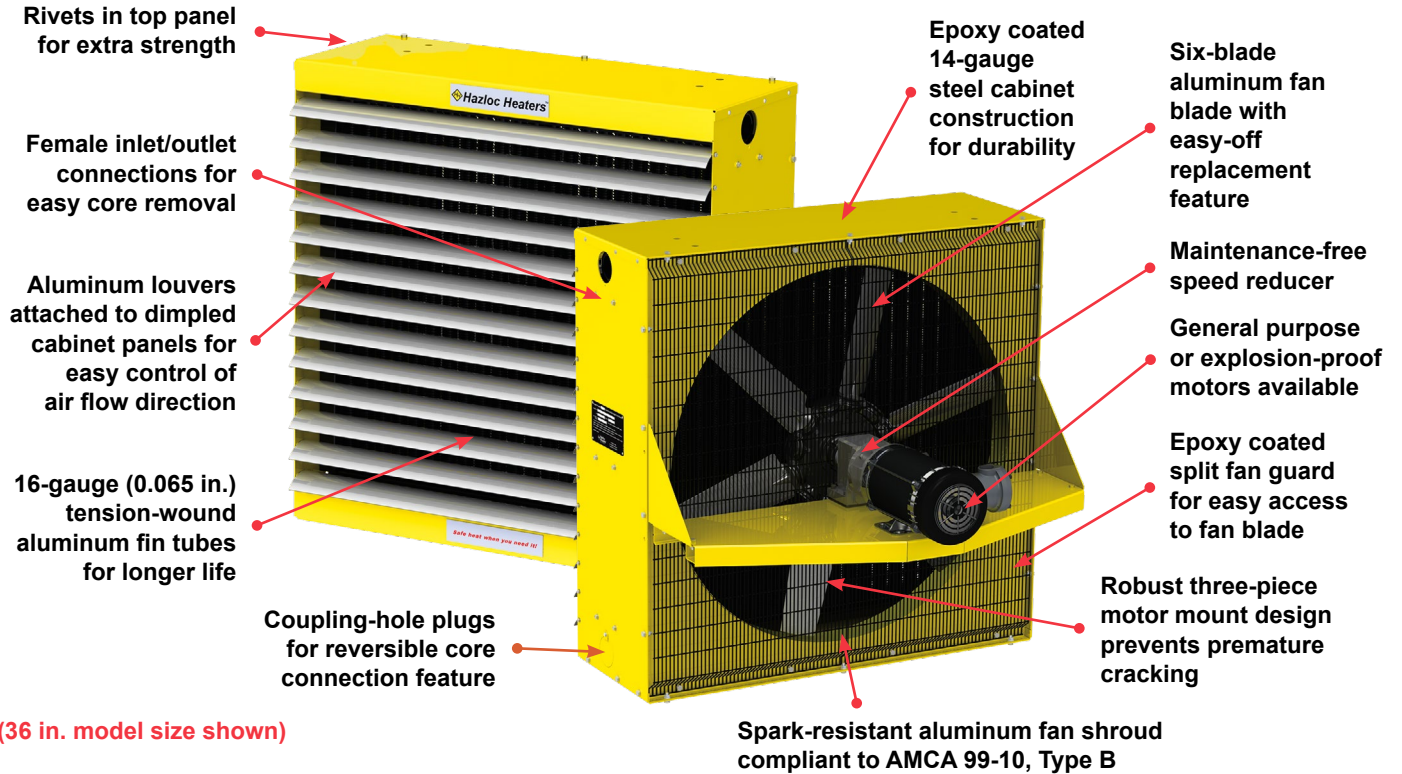

HUH2 Physical Dimensions (36 inch model)

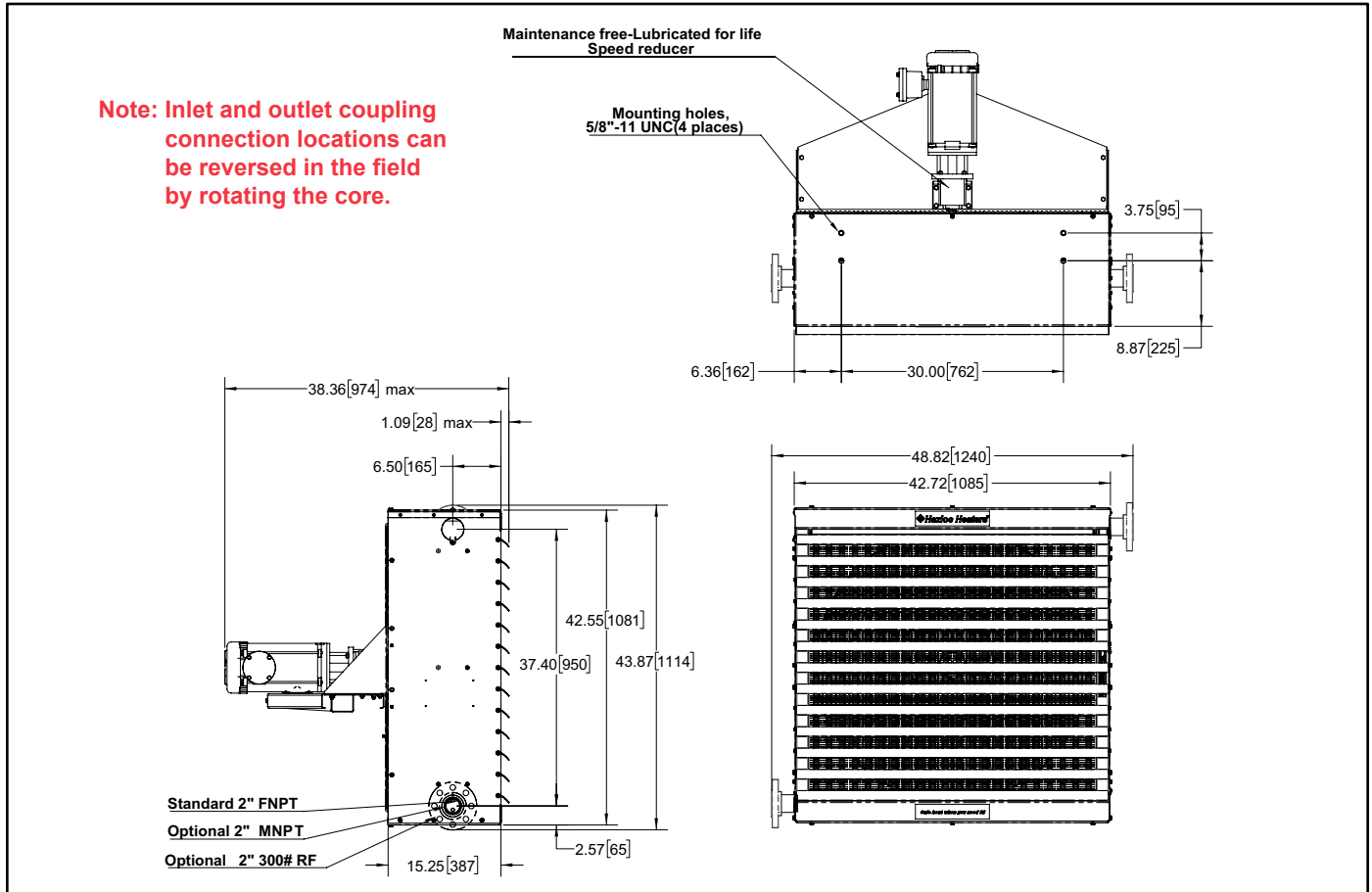

HUH2 Specifications by Model Size

Model		HUH2-12	HUH2-16	HUH2-20	HUH2-24	HUH2-30	HUH2-36
Fan diameter	in. (mm)	12 (304.8)	16 (406.4)	20 (508.0)	24 (609.6)	30 (762.0)	36 (914.4)
Air delivery*	cfm (m ³ /hr)	1090 (1852)	1650 (2803)	3000 (5097)	3800 (6456)	5500 (9344)	8350 (14186)
Approx. air velocity*	fpm (m/s)	1305 (6.6)	1111 (5.6)	1309 (6.6)	1138 (5.8)	1066 (5.4)	928 (4.7)
Air throw* @ 15 psi steam	ft (m)	45 (13.7)	65 (19.8)	70 (21.3)	80 (24.4)	85 (25.9)	70 (21.3)
Motor power	hp (watts)	¼ (186) or ½ (248)		½ (373)	½ (373)	¾ (559)	1 (746)
Rec. min. mounting height	ft (m)	7.5 (2.3)	7.5 (2.3)	7.5 (2.3)	7.5 (2.3)	7.5 (2.3)	7.5 (2.3)
Net weight (no options)	lbs (kg)	93 (42.2)	113 (51.3)	158 (71.7)	227 (103.0)	288 (130.6)	533 (241.8)
Shipping weight (no options)		143 (64.9)	165 (74.8)	216 (98.0)	292 (132.4)	363 (164.7)	645 (292.6)
with 2" NPT nipples (add)	lbs (kg)	1 (0.4)	1 (0.4)	1 (0.4)	1 (0.4)	1 (0.4)	1 (0.4)
with flanges & nipples (add)		14 (6.3)	14 (6.3)	14 (6.3)	14 (6.3)	14 (6.3)	14 (6.3)

* At 70°F (21°C), 60 Hz and sea level.

HUH2 General Specifications

Approval	CRN: 0H14933.2C - steam or fluids (not for use with lethal fluids as defined by ASME, Section VIII, Div. 1, UW-2).
Maximum pressure rating	400 psig (2758 kPa).
Maximum temperature rating	550 °F (288°C).
Minimum design metal temperature	-20° F (-29° C).
Cabinet material	14-gauge (0.075 in.) (1.9 mm) steel. HUH2-36 is 12-gauge (0.105 in. (2.7 mm) steel on top and bottom panels and motor mount. Yellow epoxy/polyester powder coated with five-stage pretreatment, including iron phosphate. Optional Heresite phenolic coating available. Option Codes H2 or H3 (includes Heresite coating of louvers & fan blade).
Louver blades	Anodized extruded aluminum.
Fan	Spark-resistant three-blade aluminum (except HUH2-30 which is two-blade and HUH2-36 which is six-blade).
Fan shroud	Spark-resistant aluminum. Compliant to AMCA 99-10, Type B.
Fan guard	Split design with close wire spacing. A 3/8 in. (9.5 mm) diameter probe will not enter.
Motor drive	Thermally protected CSA or UL Listed 1725 RPM permanently lubricated ball bearing type with 56 frame and "easy-off" fan blade replacement feature. HUH2-36 is a 56C frame motor and a maintenance-free speed reducer.
Mounting holes	5/8 in. - 11 UNC – 4 holes at top of heater (2 holes, HUH2-12).
Fluid connections	2 in. NPT female inlet and outlet (configuration of fluid connection locations can be reversed by rotating the core). Other thread-on connection types are available. They are shipped loose and must be installed on site. See Option Codes C2 or C3. (C3 connection also includes C2 connection).
Header material	12-gauge (0.105 in.) (2.7 mm) and 3/16 in. (4.8 mm) carbon steel conforming to ASME requirements.
Finned tubes	5/8 in. (15.9 mm) outside diameter [16-gauge, 0.065 in. (1.6 mm) wall thickness] carbon steel tubes with 1-1/2 in. (38.1 mm) outside diameter copper-free, L-foot, tension-wound aluminum fins @ 10 fins per in.
Exchanger coatings	Standard coating is a black, high-heat enamel paint. Optional Heresite phenolic coating available. Option Codes H1 or H3.

Accessories – Mounting Brackets



WMB*

Wall Mounting Bracket

For use in buildings that have substantial walls. The Z sections provide additional support where necessary.



BMB*

Basic Mounting Bracket

For applications where the support arm can be bolted or welded directly to structural steel or concrete.



PMB*

Pipe Mounting Bracket

For buildings with insufficient strength to use other types of mounting brackets. Requires 3 in. pipe (3.5 in. O.D., min. Sch. 40, not supplied).



HMB

Hanging Mounting Bracket

Ideal and economical if adequate overhead structure exists. Requires 1/2 in. pipe, cut and threaded (min. Sch. 40 not supplied).

Note: When ordering mounting brackets, please specify the type of bracket preferred, the basic model code and fan size of the heater to be mounted. Example, **PMB-HUH2-16**. Mounting kits are made of steel with a black enamel paint finish. Structural support of heater and bracket during transit is required. * **Not suitable for model HUH2-30 or HUH2-36.**

Thermostat, Remote Mount

ET9STS (SPST)

Line-Voltage Thermostat

22 Amps Resistive Load, 277 VAC Max

3/4 HP@125 VAC; 1-1/2 HP@ 250/277 VAC

Ship wt - 0.6 lbs (0.28 kg)



BTX2-15A-W-N-A (Bi-metal, SPDT) Heating or Cooling

Class I, Division 1 & 2, Groups B, C & D

Class II, Division 1, Groups E, F & G

Class II, Division 2, Groups F & G; Class III; T6

-50°C ≤ T amb ≤ +40°C, IP66, Type 4

Class I, Zone 1, Ex db, Groups IIA, IIB+H₂, T6, Gb

Class I, Zone 2, Ex dc, Groups IIA, IIB+H₂, T6, Gc

Class I, Zone 1, AEx db, Groups IIA, IIB+H₂, T6, Gb

Class I, Zone 2, AEx dc, Groups IIA, IIB+H₂, T6, Gc

Class II, Zone 21, Ex tb, Groups IIIA, IIIB & IIIC, T85°C, Db

Class II, Zone 22, Ex tc, Groups IIIA, IIIB & IIIC, T85°C, Dc

Class II, Zone 21, AEx tb, Groups IIIA, IIIB & IIIC, T85°C, Db

Class II, Zone 22, AEx tc, Groups IIIA, IIIB & IIIC, T85°C, Dc



Temperature adjustment range: 40°F to 80°F (5°C to 25°C); 3/4" - NPT conduit opening on top and bottom

Ship wt - 3.5 lbs (1.6 kg)

15 Amps Resistive Load, 480VAC Max; 3/4HP @ 125VAC; 1-1/2HP @ 250VAC (suitable for 24VAC or 120VAC control circuit)

Disconnect Switch, Remote Mount

XDC-01

Explosion-proof Disconnect switch

Class I, Div. 1 & 2, Grp C & D; Class II, Div. 1, Grp E, F & G; Class II, Div. 2, Grp F & G;

Class III; Class I, Zones 1 & 2, Grp IIA & IIB, T5

CSA/US - Certified to Canadian and U.S. standards

600VAC, 50A max; 15HP @ 208/240VAC, 3 phase; 30HP @ 480/600VAC, 3 phase; 2HP @ 120VAC, 1 phase; 7.5HP @ 240VAC, 1 phase

Ship wt - 12.0 lbs (5.4 kg)



How to Order

When asking for a quote or placing an order, please follow the **“Model Coding”** format on page 4 to specify your exact model code configuration. If ordering explosion-proof motors also specify hazardous location area rating required.

Example Model Code: **HUH2-16-3-N-115160-E, H3, C2, etc**
Suitable for Class I, Div. 1, Group D,
T3B atmosphere

Steam Performance Tables

HUH2-12-1-N-# @60 Hz

PSIG	°F	Performance	Entering Air Temperature								
			-10	0	10	20	30	40	50	60	70
2	219	Output (10 ³ btu/hr)	71	67	63	60	56	53	50	46	43
		Cond. (lbs/hr)	73	69	66	62	58	55	51	48	45
		FAT (°F)	40.9	49.4	57.7	66.1	74.3	82.5	90.6	98.6	106.7
50	298	Output (10 ³ btu/hr)	95	92	88	84	81	77	73	70	66
		Cond. (lbs/hr)	104	100	96	92	88	84	80	77	73
		FAT (°F)	58.8	67.5	76.2	84.7	93.2	101.6	109.9	118.2	126.4
100	338	Output (10 ³ btu/hr)	108	105	101	97	93	89	86	82	79
		Cond. (lbs/hr)	123	118	114	110	105	101	97	93	89
		FAT (°F)	68.1	76.9	85.7	94.4	103.0	111.6	120.0	128.4	136.7
150	366	Output (10 ³ btu/hr)	117	113	109	105	101	98	94	90	87
		Cond. (lbs/hr)	136	131	127	122	118	114	109	105	101
		FAT (°F)	74.3	83.2	92.1	100.9	109.6	118.2	126.8	135.3	143.7
200	387	Output (10 ³ btu/hr)	124	120	116	112	108	104	101	97	93
		Cond. (lbs/hr)	147	142	138	133	129	124	120	115	111
		FAT (°F)	79.1	88.1	97.0	105.9	114.7	123.4	132.0	140.6	149.1

- If using 50 Hz power supply, derate output values by 6%. Above figures are based on calculations at sea level.
- # Refer to page 4 to complete model code for ordering.

HUH2-16-1-N-# @60 Hz

PSIG	°F	Performance	Entering Air Temperature								
			-10	0	10	20	30	40	50	60	70
2	219	Output (10 ³ btu/hr)	112	106	101	95	89	84	79	74	69
		Cond. (lbs/hr)	116	110	104	98	92	87	82	76	71
		FAT (°F)	43.4	51.8	60.1	68.3	76.4	84.5	92.6	100.5	108.4
50	298	Output (10 ³ btu/hr)	152	146	140	134	128	122	117	111	106
		Cond. (lbs/hr)	166	160	153	146	140	134	128	122	116
		FAT (°F)	62.4	71.0	79.5	88.0	96.4	104.7	112.9	121.1	129.2
100	338	Output (10 ³ btu/hr)	173	166	160	154	148	142	136	130	125
		Cond. (lbs/hr)	195	188	181	174	168	161	154	148	141
		FAT (°F)	72.2	81.0	89.6	98.2	106.7	115.1	123.5	131.8	140.0
150	366	Output (10 ³ btu/hr)	186	180	174	168	161	155	150	144	138
		Cond. (lbs/hr)	217	209	202	195	188	181	174	167	160
		FAT (°F)	78.8	87.6	96.4	105.1	113.7	122.2	130.6	139.0	147.3
200	387	Output (10 ³ btu/hr)	197	191	184	178	172	166	160	154	148
		Cond. (lbs/hr)	235	227	219	212	205	197	190	183	176
		FAT (°F)	83.9	92.8	101.6	110.4	119.1	127.7	136.2	144.7	153.1

- If using 50 Hz power supply, derate output values by 6%. Above figures are based on calculations at sea level.
- # Refer to page 4 to complete model code for ordering.

Nomenclature

10³ – 1000

BTU – British Thermal Unit

Cond. – Condensate Flow Rate

EAT – Entering Air Temperature

ΔT – Fluid Temperature Drop

FAT – Final Air Temperature

PSIG – Pounds Per Square Inch Gauge Pressure

CFM – Cubic Feet Per Minute

USGPM – U.S. Gallons Per Minute

ΔP – Fluid Pressure Drop

Steam Performance Tables

HUH2-20-1-N-# @60 Hz

PSIG	°F	Performance	Entering Air Temperature								
			-10	0	10	20	30	40	50	60	70
2	219	Output (10 ³ btu/hr)	190	180	170	161	151	142	133	125	116
		Cond. (lbs/hr)	196	186	176	166	157	147	138	129	120
		FAT (°F)	39.8	48.1	56.5	64.9	73.2	81.4	89.6	97.7	105.8
50	298	Output (10 ³ btu/hr)	260	250	239	229	220	210	200	191	181
		Cond. (lbs/hr)	285	274	262	251	240	230	219	209	198
		FAT (°F)	58.2	66.9	75.5	84.1	92.6	101.0	109.3	117.7	125.9
100	338	Output (10 ³ btu/hr)	296	285	274	264	254	243	234	224	214
		Cond. (lbs/hr)	335	323	311	299	287	276	265	254	243
		FAT (°F)	67.4	76.3	85.0	93.7	102.3	110.8	119.3	127.7	136.0
150	366	Output (10 ³ btu/hr)	319	308	297	287	276	266	256	246	237
		Cond. (lbs/hr)	371	359	346	334	322	310	298	287	275
		FAT (°F)	73.6	82.5	91.4	100.2	108.9	117.5	126.0	134.5	142.9
200	387	Output (10 ³ btu/hr)	337	326	316	305	295	284	274	264	254
		Cond. (lbs/hr)	402	389	376	363	351	338	326	314	302
		FAT (°F)	78.4	87.4	96.3	105.2	113.9	122.3	131.3	139.8	148.3

- If using 50 Hz power supply, derate output values by 6%. Above figures are based on calculations at sea level.
- # Refer to page 4 to complete model code for ordering.

HUH2-24-1-N-# @60 Hz

PSIG	°F	Performance	Entering Air Temperature								
			-10	0	10	20	30	40	50	60	70
2	219	Output (10 ³ btu/hr)	388	367	347	327	308	289	270	252	234
		Cond. (lbs/hr)	400	379	358	338	318	298	279	260	241
		FAT (°F)	70.1	77.5	84.8	92.1	99.2	106.2	113.2	120.1	126.8
50	298	Output (10 ³ btu/hr)	540	518	495	474	452	431	410	390	370
		Cond. (lbs/hr)	591	566	542	518	495	472	449	427	405
		FAT (°F)	101.7	109.4	116.9	124.4	131.7	138.9	146.1	153.1	160.1
100	338	Output (10 ³ btu/hr)	614	591	568	545	523	501	480	459	439
		Cond. (lbs/hr)	696	669	643	618	593	568	544	520	497
		FAT (°F)	117.1	124.9	132.7	140.3	147.8	155.1	162.4	169.6	176.7
150	366	Output (10 ³ btu/hr)	665	641	618	594	572	550	528	506	486
		Cond. (lbs/hr)	773	745	718	691	665	639	614	589	565
		FAT (°F)	127.4	135.4	143.2	151.0	158.5	166.1	173.5	180.8	188.0
200	387	Output (10 ³ btu/hr)	703	679	656	632	609	587	565	543	522
		Cond. (lbs/hr)	838	809	781	753	725	699	672	647	621
		FAT (°F)	135.5	143.6	151.5	159.3	167.0	174.7	182.2	189.5	196.8

- If using 50 Hz power supply, derate output values by 6%. Above figures are based on calculations at sea level.
- # Refer to page 4 to complete model code for ordering.

Steam Performance Tables

HUH2-30-1-N# @60 Hz

PSIG	°F	Performance	Entering Air Temperature								
			-10	0	10	20	30	40	50	60	70
2	219	Output (10 ³ btu/hr)	601	569	537	506	475	446	417	388	360
		Cond. (lbs/hr)	621	587	554	522	491	461	431	401	372
		FAT (°F)	75.8	83.0	90.0	97.0	103.9	110.7	117.4	124.0	130.5
50	298	Output (10 ³ btu/hr)	818	783	749	715	683	650	619	589	559
		Cond. (lbs/hr)	894	856	819	782	747	712	677	644	611
		FAT (°F)	106.7	114.2	121.6	128.9	136.1	143.2	150.2	157.1	163.9
100	338	Output (10 ³ btu/hr)	930	894	859	824	790	757	725	693	661
		Cond. (lbs/hr)	1054	1013	973	933	895	857	821	785	749
		FAT (°F)	122.9	130.6	138.1	145.5	152.9	160.1	167.2	174.2	181.2
150	366	Output (10 ³ btu/hr)	1007	970	934	899	864	830	797	765	732
		Cond. (lbs/hr)	1171	1128	1086	1045	1005	966	927	889	852
		FAT (°F)	133.7	141.5	149.2	156.8	164.3	171.6	178.8	185.9	193.0
200	387	Output (10 ³ btu/hr)	1066	1029	992	956	921	887	854	820	787
		Cond. (lbs/hr)	1269	1224	1181	1138	1097	1056	1016	976	938
		FAT (°F)	142.2	150.1	157.9	165.6	173.2	180.6	187.9	195.1	202.3

- If using 50 Hz power supply, derate output values by 6%. Above figures are based on calculations at sea level.
- # Refer to page 4 to complete model code for ordering.

HUH2-36-1-N-# @60 Hz

PSIG	°F	Performance	Entering Air Temperature								
			-10	0	10	20	30	40	50	60	70
2	219	Output (10 ³ btu/hr)	970	917	866	815	762	713	666	619	574
		Cond. (lbs/hr)	1005	950	897	844	789	739	690	641	594
		FAT (°F)	81.3	88.2	95.1	101.8	108.0	114.5	121.0	127.3	133.5
50	298	Output (10 ³ btu/hr)	1300	1244	1189	1136	1083	1032	981	933	883
		Cond. (lbs/hr)	1427	1365	1305	1246	1188	1132	1077	1023	970
		FAT (°F)	112.3	119.6	126.8	133.9	140.9	147.8	154.6	161.3	167.8
100	338	Output (10 ³ btu/hr)	1474	1416	1358	1302	1249	1196	1144	1093	1044
		Cond. (lbs/hr)	1673	1607	1542	1479	1417	1357	1299	1241	1185
		FAT (°F)	128.6	136.1	143.4	150.6	157.8	164.9	171.9	178.7	185.5
150	366	Output (10 ³ btu/hr)	1591	1532	1474	1418	1362	1308	1255	1203	1153
		Cond. (lbs/hr)	1851	1782	1715	1649	1584	1521	1460	1399	1341
		FAT (°F)	139.6	147.3	154.8	162.2	169.4	176.6	183.6	190.6	197.5
200	387	Output (10 ³ btu/hr)	1687	1623	1564	1507	1451	1396	1342	1290	1238
		Cond. (lbs/hr)	2009	1929	1859	1791	1724	1659	1595	1533	1472
		FAT (°F)	148.6	156.0	163.6	171.1	178.5	185.7	192.9	200.0	206.9

- If using 50 Hz power supply, derate output values by 6%. Above figures are based on calculations at sea level.
- # Refer to page 4 to complete model code for ordering.

HUH2 Engineering Specifications

1.0 General

- 1.1 Heat-exchanger unit heater(s) shall be supplied and installed in accordance with the plans and specifications and shall be Hazloc Heaters' HUH2 series.
- 1.2 The unit heater(s) shall be (select one)
- suitable for steam applications operating @ _____ psi, producing _____ MBH @ entering air temperature of _____ °F and @ an altitude of _____ feet.
 - suitable for _____ (type of fluid) producing _____ MBH @ entering fluid temperature of _____ °F, exiting fluid temperature of _____ °F, entering air temperature of _____ °F and @ an altitude of _____ feet.

2.0 Heat Exchanger

- 2.1 The heat exchanger shall be constructed of carbon-steel headers conforming to ASME requirements with 5/8 in. (15.9 mm) outside diameter [16-gauge, 0.065 in. (1.6 mm) wall thickness] carbon-steel tubes with 1-1/2 in. (38.1 mm) outside diameter copper-free, L-foot, tension-wound aluminum fins @ 10 fins per in.
- 2.2 Inlet and outlet connections shall be 2" NPT female extra heavy-duty steel type. Configuration of the fluid connections shall be reversible by rotating the core.
- 2.3 The heat exchanger shall be suitable for pressures up to 400 psi (2758 kPa) and an operating temperature of 550°F (288°C).

3.0 Cabinet Assembly

- 3.1 The cabinet assembly shall be of a rivet and bolt together design using minimum 14 gauge, 0.075 in. (1.9 mm) steel with a yellow baked epoxy/polyester powder coating.
- 3.2 Louver blades shall be individually adjustable and made of anodized extruded aluminum.

4.0 Fan and Motor Assembly

- 4.1 The fan shall be an accurately balanced propeller design with spark-resistant aluminum blades riveted to a steel hub, driven directly by the motor or speed reducer on 36 in. model. The fan shroud shall be spark-resistant aluminum compliant to AMCA 99-10, Type B.
- 4.2 The fan shall be shielded with a heavy-duty steel wire, epoxy-coated guard. To provide easy maintenance and cleaning of the fan and motor, the fan guard shall be of a two piece construction. The guard shall not allow a 3/8 in. (9.5 mm) probe to enter.
- 4.3 The motor shall be heavy-duty industrial type with permanently lubricated ball bearings, and be UL Listed and/or CSA Certified. The motor or speed reducer shall provide a method for easy field replacement of fan blade assembly without the use of specific tools.

The motor shall be (select one):

- General purpose and rated for _____ volt, _____ phase, _____ hertz service.
- Explosion-proof and rated for _____ volt, _____ phase, _____ hertz service, Class _____, Div. (Zone) _____, Group(s) _____. Temp. Code _____.

5.0 Options

The heater shall include the following option:

- Heresite coated core (H1)
- Heresite coated cabinet (H2)
- Heresite coated core & cabinet (H3)
- Thread-on 2" MNPT fitting (C2) [shipped loose]
- Thread-on 2" FNPT300# RF Flange (C3) [shipped loose] This option also includes C2 connection.

Additional Products Available

Hazloc Heaters™ offers a wide variety of steam/hydronic air heaters, explosion-proof electric air heaters, washdown/corrosion resistant air heaters, non-hazardous area air heaters, air sensing thermostats, disconnect switches and other related accessories.

Please visit www.HazlocHeaters.com and click on the *Products* link.



 **Hazloc Heaters™** *“Safe heat when you need it!”*

Quality Mission Statement

Quality is... customers that come back, and products that don't.

Limited 18-Month Warranty

Hazloc Heaters™ warrants all **HUH2** series of heat-exchanger unit heaters against defects in materials and workmanship under normal conditions of use for a period of eighteen (18) months from date of purchase based on the following terms:

1. The heater must not be modified in any way.
2. The heater must be stored, installed and used only in accordance with the owner's manual and attached data plate information.
3. Replacement parts will be provided free of charge as necessary to restore any unit to normal operating condition, provided that the defective parts be returned to us freight prepaid and that the replacement parts be accepted freight collect.
4. The complete heater may be returned to our manufacturing plant for repair or replacement (at our discretion), freight charges prepaid.
5. Contamination by dirt, dust, etc. or corrosion will not be considered as defects.
6. This warranty shall be limited to the actual equipment involved and, under no circumstances, shall include or extend to installation or removal costs, or to consequential damages or losses.

 **Hazloc Heaters™**

Safe heat when you need it!

#1, 666 Goddard Ave. NE
Calgary, Alberta T2K 5X3 Canada
Tel.: +1-403-730-2488
Fax: +1-403-730-2482
Customer Toll Free (U.S. & Canada):
+1-866-701-Heat (4328)
www.HazlocHeaters.com



Available from: