



Hazloc Heaters™

Safe heat when you need it!



Includes our **PERFORMACORE™** HEAT EXCHANGER!

Vertical projection models now available!

HHP2

Hydronic High Performance Heater

CRN: 0H14856.2C
450 psig (3103 KPa)

Horizontal and Vertical Projection
Industrial Grade
Heat-Exchanger Unit Heaters

www.HazlocHeaters.com

HH Hazloc Heaters™ is a manufacturer of industrial-grade unit heaters suitable for hazardous and severe-duty locations.



The **Hydronic High Performance (HHP2)** series of heat-exchanger unit heaters is designed to meet the most demanding requirements of heavy industry. The harsh operating conditions of this industry require heating equipment that is safe, reliable, dependable, and available when you need it. The rugged design features of the **HHP2** series also makes it ideal for use in heavy-duty industries that include oil & gas, pulp & paper, power generation, mining, steel mills, foundries, water and wastewater treatment plants, chemical plants, and hazardous material storage facilities.



Designed for operating pressures up to 450 PSIG (3103 kPa)!

All **Hazloc Heaters™ HHP2** models are **designed to ASME requirements** for applications with **maximum operating pressures up to 450 PSIG (3103 kPa)**. The five sizes of **HHP2** heaters include our **PerformaCore™** high-performance heat-exchanger cores that are available in **16 model choices** of 5/8 in. O.D. fin tube with single-pass (for steam or fluids) and multi-pass configurations (for fluids only) to meet your specific requirements. Vertical projection models are available in 12 inch to 24 inch fan size models only.



HHP2 heaters are suitable for a wide variety of heating fluids and are **perfect for steam, hot water, or glycol applications**. They are also used with other non-lethal or non-poisonous fluids (as defined by ASME) for both space heating and liquid cooling applications that include but are not limited to hot-oil heaters, lube-oil coolers, product process coolers, pump-seal coolers, etc.

Rugged design, but easily maintained!

All **HHP2** heaters are designed for industrial applications with all features being heavy-duty to meet your most demanding environments and long-life expectations. Even with heavy-gauge steel construction used throughout the heater it does not inhibit maintenance of the product since all cabinet panels are easily removed.

Interchangeable with other brands of heaters!

Some of **Hazloc Heaters™ HHP** series models are designed with cabinet dimensions and mounting holes equivalent to a major competitor's heaters making them easily interchangeable. Furthermore, our rugged **HHP PerformaCore™** replacement cores are also designed to slide into equivalent sizes of their heaters. An added benefit is our 18-month heater warranty!

Maximum durability... rugged fin tubes!

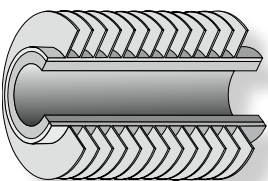

All **HHP2 PerformaCore™** heat-exchanger cores are constructed using rugged 16-gauge (0.065 in.) carbon-steel tubes with copper-free, tension-wound aluminum fins and carbon-steel headers for **maximum durability, resistance to corrosion, and longer life** in your demanding applications.

“Safe heat when you need it!”

Take advantage of our proprietary heater sizing and selection program!

Hazloc Heaters™ has developed a web-based heater sizing and selection program that will assist you with estimating your building's heating load and in selecting the right **HHP2** series of heater for your application. **Our software computes performance parameters under a diverse range of operating conditions.** Just visit www.HazlocHeaters.com and select Heater Selection Tool to register.

Hazloc Heaters™ heater selection tool is capable of rating heaters for steam, or for fluids based on either the flow-rate or temperature-drop sizing methods. **Our software is also pre-programmed with the following fluid types for quick and easy analysis.**

Steam
Water

Ethylene Glycol/Water
Diethylene Glycol/Water
Therminol 66

Triethylene Glycol/Water
Dowtherm A
Dowtherm G
Propylene Glycol/Water
and others...

Heater Specifications		For clarification of model code sequence, see product literature at www.hazlocheaters.com	
Model Code: HHP2-20-C-5-A-115160-E-F-B			
Connection Type:	1.5 inch Class 300 RF Flange (4 Bolt)		
Exchanger Coating:	High Heat Oxidant (Stainless)		
Fan Diameter:	20 inch fan diameter		
CN:	CRN (H14856 2C - steam or fluids (not for use with lethal fluids as defined by ASME, Section VIII, Div. 1, MW-2))		
Passes:	5 passes		
Motor:	115 volts, 1 phase, 60 Hz, 1/2 HP	Explosion Proof Motor, Class I & II, Div. 1 & 2, Group C, D, F, & G Temp Code T85	
	<ul style="list-style-type: none"> ■ 3/8 in. (9.5 mm) outside diameter - 18 gauge, 0.365 in. (9.3 mm) wall thickness - carbon steel tubes with 1/2 in. (12.7 mm) outside diameter copper tube. Lock tension secured aluminum fins @ 10 per inch. ■ Epoxy powder-coated carbon steel cabinet ■ Maximum operating pressure: 450 psig (3103 kPa) ■ Easy-off fan blade replacement feature ■ Mounting Brackets: None 	<ul style="list-style-type: none"> ■ 2-way anodized aluminum louvers ■ Maximum design temperature: 550°F (288°C) ■ Limited 18 month warranty ■ Accessories: None 	
Input / Output Data			
Heat Output:	238,557.00 BTU/hr	Output Per Heater:	238,557.00 BTU/hr
Quantity Required:	1		
Fluid Type:	60% Ethylene Glycol		
Flow Rate:	14.07 USGPM		
Inlet Fluid Temp:	240.0 °F	Outlet Fluid Temp:	200.0 °F
EAT:	40.0 °F	FAT:	100.0 °F
Operating Pressure (Gauge):	50.00 PSI	Pressure Drop:	1.20 PSI
Altitude:	1000 ft ASL		

Once you know your heating load, all you require is the following input data!

- Type of fluid used
- Operating pressure
- Inlet fluid temperature (liquid applications only)
- Outlet fluid temperature, or available fluid flow rate
- Altitude above sea level (ASL)
- Entering air temperature

If your fluid isn't listed in our program, we can still help!

You can still size our heaters using other fluids not listed above by **manually inputting the following fluid physical properties: Temperature, Density, Specific Heat, Thermal Conductivity, and Viscosity** at two reference points.

This brochure was produced using Imperial units of measure. If required we can provide you with data in Metric units.

Horizontal and Vertical Projection Models Available



Horizontal Projection Model
Available in 12 to 30 inch fan sizes
(Shown with adjustable one-way louvers)



Vertical Projection Model
Available in 12 to 24 inch fan sizes
(Shown with optional two-way louvers)
(VHMB mounting bracket *not* included)



Vertical Projection Model
Available in 12 to 24 inch fan sizes
(Shown with optional nozzle)
(VHMB mounting bracket *not* included)



Vertical Projection Model
Available in 12 to 24 inch fan sizes
(Shown with optional four-way louvers)
(VHMB mounting bracket *not* included)

HHP2 Model Coding

Heater Model Code & Option Codes

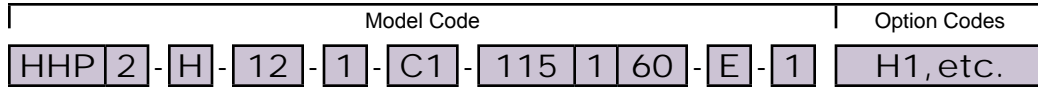

Model Series

Generation	For major revisions
------------	---------------------

Projection Type	
Horizontal	H
Vertical	V

Available in all fan sizes
Not available in 30 inch fan size

Fan Size	
12 inches	12
16 inches	16
20 inches	20
24 inches	24
30 inches	30

Horizontal or Vertical projection type
Horizontal or Vertical projection type
Horizontal or Vertical projection type
Horizontal or Vertical projection type
Horizontal protection type only

Tube Passes	
1 Pass	1
3 Pass	3
5 Pass	5
7 Pass	7

Steam units are 1 Pass only
Not available on 12 inch fan size
Not available in 12, 16, & 20 inch fan sizes

Connection Type	
1-1/2" NPT Male Sched. 40	C1
1-1/2" CL300# RF flange (4 bolt)	C2
2" CL300# RF flange (8 bolt)	C3 [△]

Options	
H1 [◇]	Heresite coated core
H2 [◇]	Heresite coated cabinet
H3 [◇]	Heresite coated core & cabinet
ZZ	Special build (Factory assigned code)

Includes louvers and fan blade

Includes louvers and fan blade

Discharge Type (Refer to Page 7)	
1	One-way adjustable louvers
2	Two-way adjustable louvers
3	Nozzle [△]
4	Four-way adjustable louvers [△]

12 to 24 inch fan size only

12 to 24 inch fan size only

12 to 24 inch fan size only

Motor Type	
G	General purpose
E [†]	Hazardous location

Motor ^{*†}		
Voltage	Phase	Frequency
115	1	60
208	1	60
230	1	60
208	3	60
230	3	60
460	3	60
575	3	60

[△] 2" 300# ANSI blind RF flange with 1-1/2" diameter hole machined in center (eight 3/4" bolt holes).

[◇] Contact factory for extended shipping lead times on Heresite coatings.

[△] Longer lead times may apply for Nozzle and Four-way adjustable louvers. Contact factory.

[†] Standard Marathon NEMA ex-proof motor is suitable for Class I & II, Div. 1 & 2, Groups C, D, F & G; T3B; Maximum ambient air temp of 40°C. Ensure equipment meets the requirements of your hazardous location.

^{*} Other voltages/frequencies available upon request. Longer lead times may apply. Contact factory.

[‡] NEMA motors are designed to be operated at rated voltage with tolerances of ± 10%. If the motor is marked 208-230V the tolerance must be calculated from 230V. If motor is marked 230V it is still suitable for 208V operation but the tolerance must be calculated from 230V. For 3-phase motors the line to line full load voltage must be balanced within 1%.



How to Order

When asking for a quote or placing an order, please follow the "**Model Coding**" format above to specify your exact model code configuration. If ordering explosion-proof motors also specify hazardous location area rating required.

Example Model Code: HHP2-V-16-1-C1-115160-E-3 H1
Suitable for Class I, Div. 1,
Group D, T3B atmosphere

HHP2 Horizontal and Vertical Projection Heaters (12 inch to 24 inch fan size models)

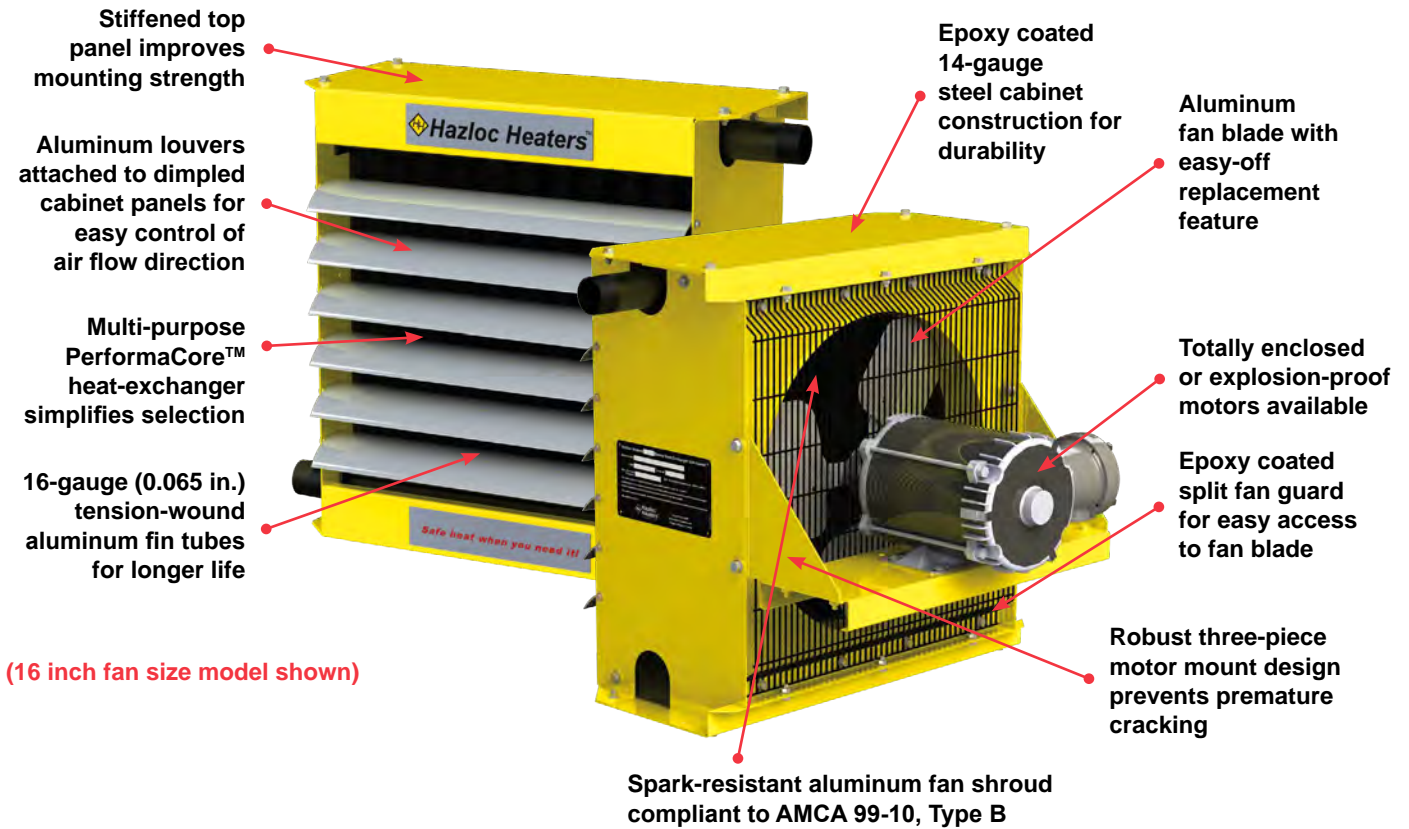

HHP2 Physical Dimensions (12 inch to 24 inch fan size models)

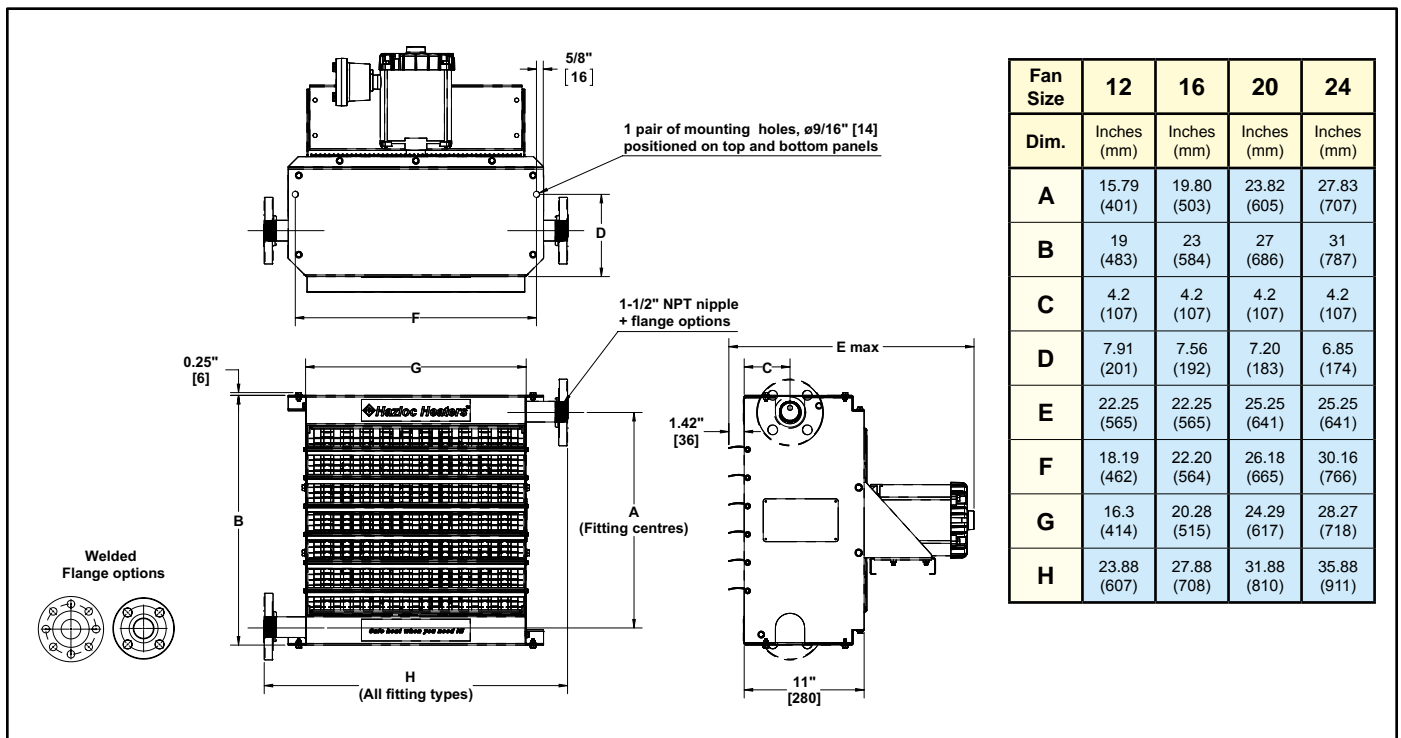

HHP2 Horizontal Projection Heaters (30 inch fan size model)

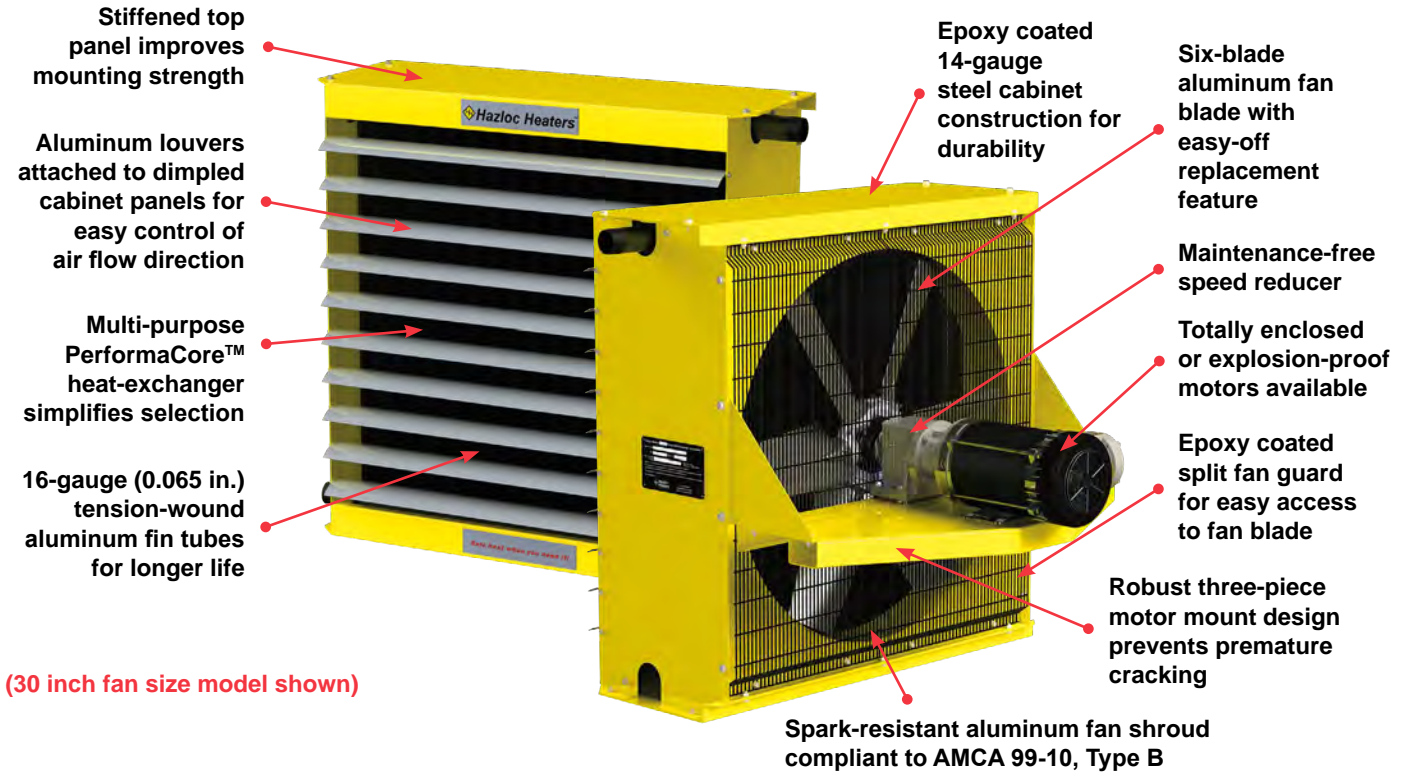

HHP2 Physical Dimensions (30 inch fan size model)

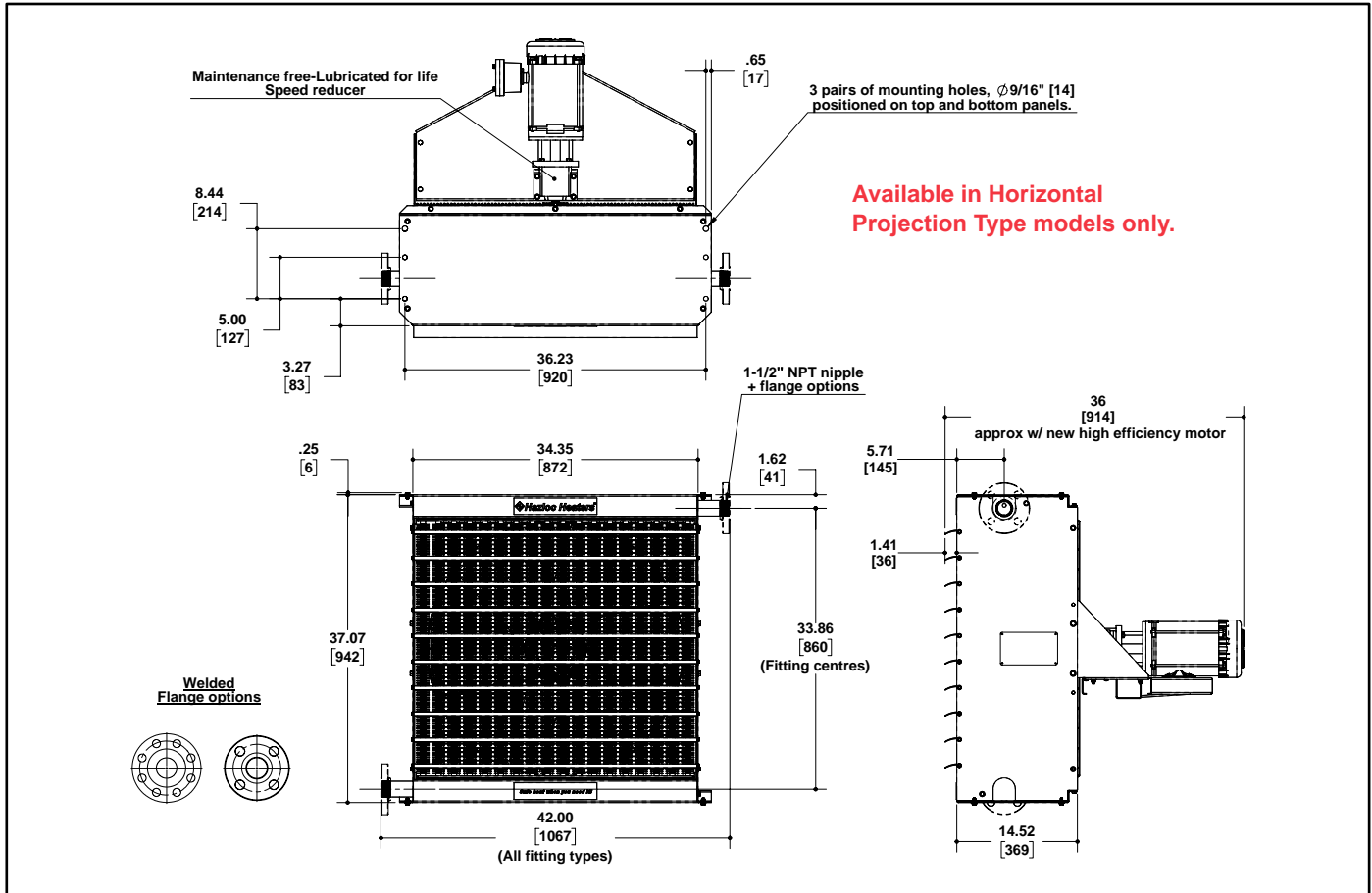

HHP2 Discharge Type Physical Dimensions

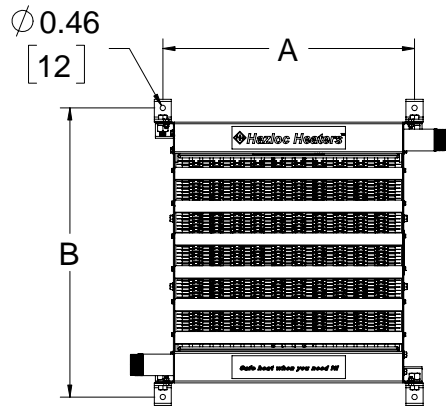

One-Way Adjustable Louvers

Recommended for Horizontal Projection Type models only

Discharge Type

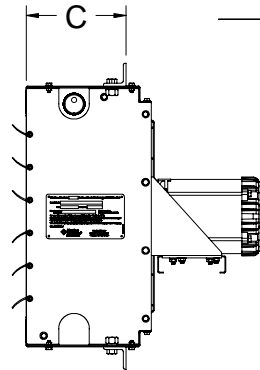

Two-Way Adjustable Louvers

(Middle louver blade is removed on models with an odd number of louver blades.)

Vertical Hanging Mounting Bracket (VHMB) Kit Optional

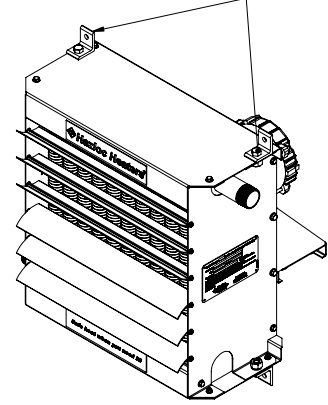

Fan Size	12	16	20	24
Dim.	Inches (mm)	Inches (mm)	Inches (mm)	Inches (mm)
A	18.19 (462)	22.20 (564)	26.18 (665)	30.16 (766)
B	21.50 (546)	25.50 (648)	29.50 (749)	33.50 (851)
C	8.80 (224)	8.80 (224)	8.80 (224)	8.80 (224)
D	12.36 (314)	12.36 (314)	16.46 (418)	16.46 (418)
E	33.19 (843)	33.19 (843)	39.26 (997)	39.26 (997)
F	24.69 (627)	24.69 (627)	26.66 (677)	26.66 (677)

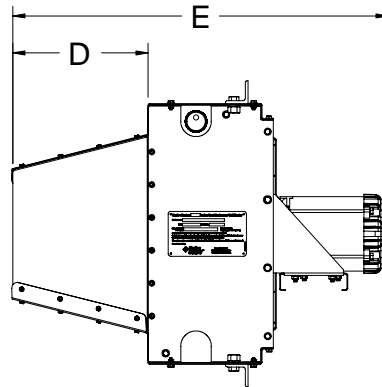

Nozzle

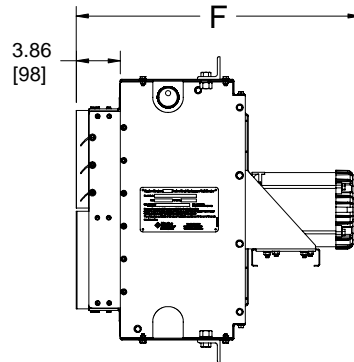
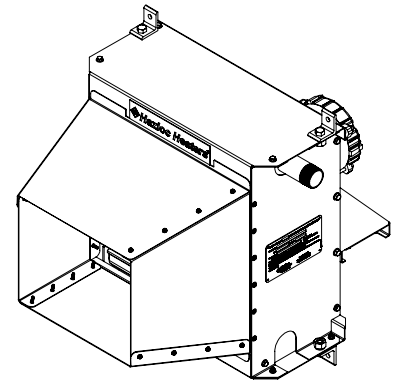

Four-Way Adjustable Louvers

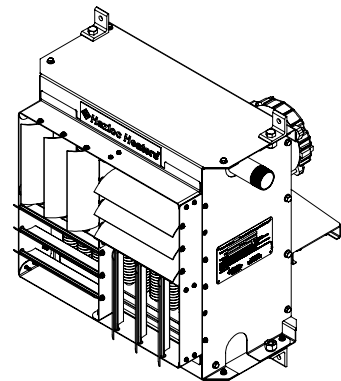

Notes:

- Two-way adjustable louvers, four-way adjustable louvers and nozzle are not available on the 30 inch fan size models.
- All views are showing optional VHMB mounting bracket kit.

HHP2 Specifications by Fan Size Model and Discharge Type

Model		HHP2-12	HHP2-16	HHP2-20	HHP2-24	HHP2-30
Fan diameter	in. (mm)	12 (304.8)	16 (406.4)	20 (508.0)	24 (609.6)	30 (762.0)
Air delivery *	cfm (m ³ /hr)	1024 (1740)	1665 (2829)	3225 (5479)	4590 (7798)	7300 (12403)
Motor power	hp (watts)	1/4 (186) or 1/3 (248)	1/4 (186) or 1/3 (248)	1/2 (373)	1/2 (373)	1 (746)
Horizontal Projection Type with One-Way Louvers						
Horizontal air velocity *	fpm (m/s)	1227 (6.2)	1139 (5.8)	1425 (7.2)	1417 (7.2)	1715 (8.7)
Horizontal air throw **	ft (m)	41 (12.5)	49 (14.9)	68 (20.7)	74 (22.6)	78 (23.8)
Max. mounting height **	ft (m)	12 (3.7)	14 (4.3)	18 (5.5)	22 (6.7)	24 (7.3)
Vertical Projection Type with Two-Way Louvers (maximum mounting height is also maximum vertical air throw)						
Max. mounting height **	ft (m)	17 (5.2)	20 (6.1)	27 (8.2)	29 (8.8)	N/A
Spread **	ft (m)	17 (5.2)	20 (6.1)	27 (8.2)	29 (8.8)	N/A
Vertical Projection Type with Nozzle (maximum mounting height is also maximum vertical air throw)						
Max. mounting height **	ft (m)	34 (10.4)	42 (12.8)	49 (14.9)	57 (17.4)	N/A
Spread **	ft (m)	13 (4.0)	16 (4.9)	19 (5.8)	23 (7.0)	N/A
Vertical Projection Type with Four-Way Louvers (maximum mounting height is also maximum vertical air throw)						
Max. mounting height **	ft (m)	12 (3.7)	15 (4.8)	17 (5.2)	20 (6.1)	N/A
Spread **	ft (m)	12 (3.7)	15 (4.8)	17 (5.2)	20 (6.1)	N/A
Weights and Shipping Crate Dimensions (wood packaging material is in compliance with ISPM No. 15)						
Net before adders	lbs (kg)	102 (46.3)	131 (59.4)	168 (76.2)	219 (99.3)	354 (160.6)
Shipping before adders	lbs (kg)	152 (68.9)	183 (83.0)	227 (103.0)	280 (127.0)	465 (210.9)
Add for flanges	lbs (kg)	16 (7.3)	16 (7.3)	16 (7.3)	16 (7.3)	16 (7.3)
Add for nozzle	lbs (kg)	10 (4.5)	12 (5.4)	19 (8.6)	20 (9.1)	N/A
Add for four-way louver	lbs (kg)	6 (2.7)	8 (3.6)	10 (4.5)	10 (4.5)	N/A
Crate W x D x H	in mm	28.0 x 29.5 x 27.75 711 x 749 x 705	31.5 x 29.5 x 31.75 800 x 749 x 806	35.5 x 29.5 x 35.75 902 x 749 x 908	39.5 x 29.5 x 39.75 1003 x 749 x 1010	48.25 x 43.0 x 45.9 1225 x 1092 x 1166

* At 70°F (21°C), 60 Hz and sea level.

† The Air throws, Spreads and Max. Mounting heights listed above are based on an air temperature rise (ΔT) of 40°F. To determine these figures for temperature rises other than 40°F, first determine the actual air temperature rise from the performance tables on the following pages, our web based Heater Selection Tool, or factory supplied printouts, and then multiply the respective values by the Correction factor in the table below.

Air Discharge Temperature Correction Factors @ Various Temperature Differences ΔT (°F)																
Actual ΔT	0	10	20	30	40	50	60	70	80	90	100	110	120	130	140	150
Correction	1.24	1.18	1.12	1.06	1.00	0.94	0.88	0.82	0.76	0.70	0.64	0.58	0.51	0.45	0.39	0.33

HHP2 General Specifications

Approval	CRN: 0H14856.2C - steam or fluids (not for use with lethal fluids as defined by ASME, Section VIII, Div. 1, UW-2).
Max. pressure rating	450 psig (3103 kPa).
Max. design temperature	550 °F (288°C).
Minimum design metal temperature	-20° F (-29° C).
Cabinet material	14-gauge (0.075 in.) (1.9 mm) steel. HHP2-30 is 12-gauge (0.105 in. (2.7 mm) steel on top and bottom panels and motor mount. Yellow epoxy/polyester powder coated with five-stage pretreatment, including iron phosphate. Optional Heresite phenolic coating available. Option Codes H2 or H3.
Louver blades	Anodized extruded aluminum.
Fan	Spark-resistant three-blade aluminum (except HHP2-30 which is six-blade).
Fan Shroud	Spark-resistant aluminum. Compliant to AMCA 99-10, Type B.
Fan guard	Split design with close wire spacing. A 3/8 in. (9.5 mm) diameter probe will not enter.
Motor drive	Thermally protected CSA or UL Listed 1725 RPM permanently lubricated ball bearing type with 56 frame and "easy-off" fan blade replacement feature. HHP2-30 is a 56C frame motor and a maintenance-free speed reducer.
Mounting holes	9/16 in. diameter holes - Two at top and two at bottom of heater.
Fluid connections	1-1/2 in. NPT male Schedule 40 inlet and outlet. Optional 1-1/2" (4 bolt) & 2" (8 bolt) CL300# RF flanges available. [see ^ symbol on Page 4 for 8 bolt description]
Header material	3/16 in. (4.8 mm) carbon steel conforming to ASME requirements.
Finned tubes	5/8 in. (15.9 mm) outside diameter [16-gauge, 0.065 in. (1.6 mm) wall thickness] carbon steel tubes with 1-1/2 in. (38.1 mm) outside diameter copper-free, L-foot, tension-wound aluminum fins @ 10 fins per in.
Exchanger coatings	Standard coating is a black, high-heat enamel paint. Optional Heresite phenolic coating available. Option Codes H1 or H3.

Accessories

Mounting Brackets



WMB*
Wall Mounting Bracket
 For use in buildings that have substantial walls. The Z sections provide additional support where necessary.



BMB*
Basic Mounting Bracket
 For applications where the support arm can be bolted or welded directly to structural steel or concrete.



PMB*
Pipe Mounting Bracket
 For buildings with insufficient strength to use other types of mounting brackets. Requires 3 in. pipe (3.5 in. O.D., min. Sch. 40, not supplied).



HMB
Hanging Mounting Bracket
 Ideal and economical if adequate overhead structure exists. Requires 1/2 in. pipe, cut and threaded (min. Sch. 40 not supplied).

VHMB*
Vertical Hanging Mounting Bracket
 Ideal and economical if adequate overhead structure exists. Use for mounting 12 to 24 inch fan size vertical projection heaters. Requires four 3/8" or 10 mm threaded rods, eight nuts and four lock washers (Discharge nozzle not included).



* Not suitable for 30 inch fan size models

Note: When ordering mounting brackets, please specify the type of bracket preferred, the basic model code and fan size of the heater to be mounted. Example, PMB-HHP2-16. Mounting kits are made of steel with a black enamel paint finish. Structural support of heater and bracket during transit is required.

Thermostat, Remote Mount

ET9STS (SPST)

Line-Voltage Thermostat
 22 Amps Resistive Load, 277 VAC Max
 3/4 HP@125 VAC; 1-1/2 HP@ 250/277 VAC
 Ship wt - 0.6 lbs (0.28 kg)



BTX2-15A-W-N-A (Bi-metal, SPDT) Heating or Cooling

Class I, Division 1 & 2, Groups B, C & D	Class I, Zone 1 & 2, Ex db, Groups IIA, IIB+H ₂ , T6, Gb
Class II, Division 1, Groups E, F & G	Class I, Zone 1 & 2, AEx db, Groups IIA, IIB+H ₂ , T6, Gb
Class II, Division 2, Groups F & G; Class III; T6	Class II, Zone 21 & 22, Ex tb, Groups IIIA, IIIB & IIIC, T85°C, Db
-50°C ≤ T amb ≤ +40°C, IP66, Type 4	Class II, Zone 21 & 22, AEx tb, Groups IIIA, IIIB & IIIC, T85°C, Db

Temperature adjustment range: 40°F to 80°F (5°C to 25°C); 3/4" - NPT conduit opening on top and bottom
 Ship wt - 3.5 lbs (1.6 kg)
 15 Amps Resistive Load, 480VAC Max; 3/4HP @ 125VAC; 1-1/2HP @ 250VAC (suitable for 24VAC or 120VAC control circuit)



Disconnect Switch, Remote Mount

XDC-01

Explosion-proof Disconnect switch
 Class I, Div. 1 & 2, Grp C & D; Class II, Div. 1, Grp E, F & G; Class II, Div. 2, Grp F & G;
 Class III; Class I, Zones 1 & 2, Grp IIA & IIB, T5
 CSA_{C/US} - Certified to Canadian and U.S. standards
 600VAC, 50A max; 15HP @ 208/240VAC, 3 phase; 30HP @ 480/600VAC, 3 phase; 2HP @ 120VAC, 1 phase; 7.5HP @ 240VAC, 1 phase
 Ship wt - 12.0 lbs (5.4 kg)



Steam Performance Tables

HHP2-?-12-1-# @60Hz

PSIG	°F	Performance	Entering Air Temperature								
			-10	0	10	20	30	40	50	60	70
2	219	Output (10 ³ btu/hr)	120	114	107	101	95	89	83	77	72
		Cond. (lbs/hr)	124	117	111	105	98	92	86	80	74
		FAT (°F)	82.3	89.2	96.0	102.8	109.4	115.8	122.2	128.5	134.7
50	298	Output (10 ³ btu/hr)	164	157	150	143	137	130	124	118	112
		Cond. (lbs/hr)	179	172	164	157	150	142	136	129	122
		FAT (°F)	115.7	123.0	130.1	137.2	144.1	150.9	157.6	164.2	170.7
100	338	Output (10 ³ btu/hr)	187	179	172	165	158	152	145	139	132
		Cond. (lbs/hr)	211	203	195	187	179	172	164	157	150
		FAT (°F)	133.2	140.6	147.9	155.0	162.1	169.1	176.0	182.7	189.4
150	366	Output (10 ³ btu/hr)	202	195	187	180	173	166	160	153	147
		Cond. (lbs/hr)	235	226	218	209	201	193	185	178	170
		FAT (°F)	145.0	152.6	160.0	167.2	174.4	181.6	188.5	195.4	202.2
200	387	Output (10 ³ btu/hr)	214	206	199	192	184	177	171	164	158
		Cond. (lbs/hr)	255	246	237	228	219	211	203	195	187
		FAT (°F)	154.2	161.9	169.4	176.8	184.1	191.2	198.3	205.3	212.1
300	421	Output (10 ³ btu/hr)	233	225	217	210	202	195	188	181	175
		Cond. (lbs/hr)	288	278	269	259	250	242	233	225	216
		FAT (°F)	168.3	176.2	183.9	191.4	198.9	206.2	213.4	220.5	227.5

- If using 50 Hz power supply, derate output values by 6%. Above figures are based on calculations at sea level.
- ? Select "H" for Horizontal or "V" for Vertical projection on 12 to 24 inch fan sizes.
- # Refer to Page 4 to complete model code for ordering.

HHP2-?-16-1-# @60Hz

PSIG	°F	Performance	Entering Air Temperature								
			-10	0	10	20	30	40	50	60	70
2	219	Output (10 ³ btu/hr)	193	182	172	178	152	143	133	124	115
		Cond. (lbs/hr)	199	188	178	183	157	147	137	128	119
		FAT (°F)	81.0	87.8	94.8	89.3	108.2	114.7	121.2	127.5	133.8
50	298	Output (10 ³ btu/hr)	263	251	240	230	219	209	198	189	179
		Cond. (lbs/hr)	287	275	263	251	239	228	217	206	195
		FAT (°F)	113.9	121.2	128.4	135.4	142.4	149.3	156.0	162.7	169.2
100	338	Output (10 ³ btu/hr)	299	287	276	265	254	243	232	222	212
		Cond. (lbs/hr)	338	325	312	299	287	275	263	251	240
		FAT (°F)	131.1	138.6	145.9	153.1	160.1	167.3	174.2	181.0	187.6
150	366	Output (10 ³ btu/hr)	324	312	300	289	277	266	256	245	235
		Cond. (lbs/hr)	376	362	349	335	322	309	297	285	273
		FAT (°F)	142.8	150.4	157.8	165.1	172.3	179.5	186.5	193.5	200.3
200	387	Output (10 ³ btu/hr)	343	331	319	307	296	285	274	263	253
		Cond. (lbs/hr)	408	394	379	365	352	338	325	313	300
		FAT (°F)	151.9	159.6	167.1	174.6	181.9	189.0	196.1	203.2	210.1
300	421	Output (10 ³ btu/hr)	373	360	348	336	325	313	302	291	280
		Cond. (lbs/hr)	462	446	431	416	402	387	373	360	347
		FAT (°F)	165.9	173.8	181.5	189.1	196.5	203.9	211.1	218.2	225.3

- If using 50 Hz power supply, derate output values by 6%. Above figures are based on calculations at sea level.
- ? Select "H" for Horizontal or "V" for Vertical projection on 12 to 24 inch fan sizes.
- # Refer to Page 4 to complete model code for ordering.

Steam Performance Tables

HHP2-?-20-1-# @60Hz

PSIG	°F	Performance	Entering Air Temperature								
			-10	0	10	20	30	40	50	60	70
2	219	Output (10 ³ btu/hr)	335	317	300	282	265	249	232	217	201
		Cond. (lbs/hr)	346	327	309	291	274	257	240	223	207
		FAT (°F)	71.7	79.0	86.2	93.3	100.4	107.3	114.1	120.9	127.6
50	298	Output (10 ³ btu/hr)	456	437	418	399	381	363	346	328	312
		Cond. (lbs/hr)	498	477	456	436	416	397	378	359	341
		FAT (°F)	101.0	108.7	116.2	123.7	131.0	138.2	145.4	152.4	159.3
100	338	Output (10 ³ btu/hr)	519	499	480	460	441	423	405	387	370
		Cond. (lbs/hr)	587	564	542	520	499	478	458	438	418
		FAT (°F)	116.3	124.1	131.8	139.4	146.9	154.3	161.6	168.8	175.9
150	366	Output (10 ³ btu/hr)	561	541	521	501	482	463	445	427	409
		Cond. (lbs/hr)	652	628	605	582	560	538	517	496	475
		FAT (°F)	126.7	134.6	142.5	150.2	157.8	165.3	172.7	179.9	187.1
200	387	Output (10 ³ btu/hr)	594	574	553	533	514	495	476	458	440
		Cond. (lbs/hr)	707	682	658	634	611	588	566	544	523
		FAT (°F)	134.7	142.8	150.7	158.5	166.2	173.8	181.3	188.7	195.9
300	421	Output (10 ³ btu/hr)	645	624	603	583	563	544	525	505	487
		Cond. (lbs/hr)	798	772	746	721	697	673	649	626	603
		FAT (°F)	147.1	155.3	163.4	171.4	179.2	186.9	194.6	202.1	209.5

- If using 50 Hz power supply, derate output values by 6%. Above figures are based on calculations at sea level.
- ? Select "H" for Horizontal or "V" for Vertical projection on 12 to 24 inch fan sizes.
- # Refer to Page 4 to complete model code for ordering.

HHP2-?-24-1-# @60Hz

PSIG	°F	Performance	Entering Air Temperature								
			-10	0	10	20	30	40	50	60	70
2	219	Output (10 ³ btu/hr)	471	446	421	396	373	349	326	304	282
		Cond. (lbs/hr)	486	460	434	409	384	360	337	313	291
		FAT (°F)	70.6	77.9	85.2	92.3	99.4	106.4	113.3	120.0	126.8
50	298	Output (10 ³ btu/hr)	640	613	586	560	535	510	485	461	438
		Cond. (lbs/hr)	700	670	641	612	584	557	530	504	478
		FAT (°F)	99.6	107.2	114.8	122.3	129.6	136.9	144.1	151.2	158.1
100	338	Output (10 ³ btu/hr)	729	701	673	646	619	593	568	543	519
		Cond. (lbs/hr)	824	792	761	730	701	671	642	614	587
		FAT (°F)	114.6	122.5	130.2	137.9	145.4	152.8	160.1	167.3	174.4
150	366	Output (10 ³ btu/hr)	788	759	731	704	677	651	625	599	575
		Cond. (lbs/hr)	916	882	850	818	786	756	726	696	667.5
		FAT (°F)	124.8	132.8	140.7	148.4	156.0	163.6	171.0	178.3	185.5
200	387	Output (10 ³ btu/hr)	835	806	777	749	722	695	669	643	618
		Cond. (lbs/hr)	992	958	924	891	858	826	795	764	734
		FAT (°F)	132.8	140.8	148.8	156.6	164.4	172.0	179.5	186.9	194.3
300	421	Output (10 ³ btu/hr)	905	876	847	819	791	763	736	710	684
		Cond. (lbs/hr)	1120	1084	1048	1013	978	944	911	879	847
		FAT (°F)	144.9	153.1	161.3	169.3	177.2	184.9	192.6	200.2	207.6

- If using 50 Hz power supply, derate output values by 6%. Above figures are based on calculations at sea level.
- ? Select "H" for Horizontal or "V" for Vertical projection on 12 to 24 inch fan sizes.
- # Refer to Page 4 to complete model code for ordering.

Steam Performance Tables

HHP2-H-30-1-# @60Hz

PSIG	°F	Performance	Entering Air Temperature								
			-10	0	10	20	30	40	50	60	70
2	219	Output (10 ³ btu/hr)	732	692	652	615	579	543	508	473	439
		Cond. (lbs/hr)	758	717	676	637	600	563	526	490	455
		FAT (°F)	68.8	76.1	83.3	90.7	97.9	104.9	111.9	118.8	125.7
50	298	Output (10 ³ btu/hr)	991	948	906	865	825	791	750	713	677
		Cond. (lbs/hr)	1088	1041	995	950	905	864	823	783	743
		FAT (°F)	96.6	104.3	111.8	119.3	126.6	134.5	141.4	148.6	155.7
100	338	Output (10 ³ btu/hr)	1130	1086	1039	996	955	914	879	838	801
		Cond. (lbs/hr)	1281	1232	1180	1131	1084	1039	998	952	910
		FAT (°F)	111.5	119.5	126.8	134.3	141.8	149.2	157.1	164.2	171.4
150	366	Output (10 ³ btu/hr)	1218	1176	1132	1085	1043	1001	962	924	885
		Cond. (lbs/hr)	1420	1367	1317	1264	1214	1166	1123	1075	1031
		FAT (°F)	121.1	129.3	137.2	144.0	152.1	159.5	167.2	174.7	182.1
200	387	Output (10 ³ btu/hr)	1288	1243	1202	1158	1116	1074	1032	993	951
		Cond. (lbs/hr)	1534	1481	1427	1375	1326	1278	1226	1183	1131
		FAT (°F)	128.6	136.7	145.0	152.8	160.6	168.3	175.7	183.4	190.3
300	421	Output (10 ³ btu/hr)	1400	1353	1303	1258	1216	1172	1129	1096	1049
		Cond. (lbs/hr)	1727	1670	1608	1555	1500	1445	1391	1343	1299
		FAT (°F)	140.5	148.7	156.3	164.3	172.4	180.0	187.5	196.1	202.8

- If using 50 Hz power supply, derate output values by 6%. Above figures are based on calculations at sea level.
- # Refer to Page 4 to complete model code for ordering.

Nomenclature/Formulas/Conversions

10³ – 1000

BTU – British Thermal Unit

Cond. – Condensate Flow Rate

EAT – Entering Air Temperature

ΔT – Fluid Temperature Drop

FAT – Final Air Temperature

PSIG – Pounds Per Square Inch Gauge Pressure

CFM – Cubic Feet Per Minute

USGPM – U.S. Gallons Per Minute

ΔP – Fluid Pressure Drop

$$\text{Condensate (lbs/hr)} = \frac{\text{actual btu/hr}}{\text{Latent Heat of Steam @ PSIG}}$$

1 **U.S. Gallon of water** = 8.34 lbs of water

1 **U.S. Gallon** = .8327 Imperial Gallons

1 **kW** = 3,414 btu/hr

1 **Boiler HP** = 33,478.8 btu/hr @ 70 psi

Properties of Steam			
Gauge Pressure (PSIG)	Temp. (°F)	Latent Heat (btu/lb)	Density (lb/ft ³)
2	219	965	.0434
10	239	952	.0612
20	259	939	.0855
40	287	919	.1351
50	298	912	.1498
60	307	904	.1818
80	324	891	.2127
100	338	880	.2564
150	366	857	.3634
200	387	838	.4686
300	422	805	.6803
450	460	764	1.0

Glycol Performance Tables - 50% Ethylene Glycol[†], 60°F EAT @60 Hz

		Entering Glycol Temperature															
		180°F				200°F				220°F				240°F			
Model	ΔT °F	Output 10 ³ Btu/Hr	FLOW USGPM	FAT °F	ΔP PSI	Output 10 ³ Btu/Hr	FLOW USGPM	FAT °F	ΔP PSI	Output 10 ³ Btu/Hr	FLOW USGPM	FAT °F	ΔP PSI	Output 10 ³ Btu/Hr	FLOW USGPM	FAT °F	ΔP PSI
HHP2-?-12-1-# 1 Pass Heater	10	26	6.15	83.0	0.01	34	8.05	90.4	0.01	49	11.3	103.0	0.02	62	14.4	114.9	0.02
	20	23	2.77	80.6	0.00	29	3.45	86.0	0.00	36	4.16	91.7	0.00	42	4.92	97.6	0.01
	40	20	1.17	77.3	0.00	25	1.50	82.5	0.00	32	1.85	88.0	0.00	38	2.21	93.8	0.00
HHP2-?-12-3-# 3 Pass Heater	10	46	11.0	101.1	0.35	58	13.7	111.7	0.51	70	16.3	122.2	0.69	82	19.0	132.6	0.91
	20	28	3.28	84.6	0.05	43	5.05	98.2	0.09	55	6.45	109.2	0.13	68	7.86	120.2	0.18
	40	20	1.22	78.3	0.02	26	1.56	83.5	0.02	33	1.92	89.3	0.03	41	2.37	96.5	0.03
HHP2-?-16-1-#* 1 Pass Heater	10	41	9.73	82.3	0.02	68	15.9	97.0	0.04	88	20.5	108.0	0.05	108	24.8	118.8	0.06
	20	37	4.38	80.0	0.02	46	5.46	85.3	0.02	57	6.59	90.8	0.02	67	7.71	96.5	0.02
	40	31	1.85	76.8	0.12	40	2.37	81.8	0.12	50	2.92	87.2	0.12	58	3.37	91.8	0.12
HHP2-?-16-3-# 3 Pass Heater	10	79	18.7	102.9	0.68	97	22.9	113.1	0.97	116	2.48	123.3	1.30	135	30.9	133.4	1.66
	20	57	6.85	91.4	0.12	77	9.07	102.0	0.19	96	11.2	112.7	0.27	116	13.3	123.2	0.39
	40	32	1.95	77.8	0.03	42	2.48	83.0	0.04	56	3.26	90.5	0.04	79	4.56	103.1	0.06
HHP2-?-16-5-# 5 Pass Heater	10	88	20.9	102.0	3.60	107	25.1	111.0	5.02	125	29.1	119.9	6.64	144	33.1	128.7	8.38
	20	72	8.58	94.7	0.69	91	10.8	103.9	1.03	111	12.9	113.1	1.42	130	15.0	122.3	1.85
	40	34	2.07	76.8	0.07	61	3.64	90.0	0.16	82	4.81	99.8	0.24	102	5.93	109.5	0.34
HHP2-?-20-1-#* 1 Pass Heater	10	97	23.0	87.2	0.14	131	30.9	97.0	0.16	166	38.6	106.8	0.19	201	46.1	116.4	0.22
	20	58	6.98	76.5	0.11	74	8.74	80.9	0.11	98	11.4	87.6	0.11	135	15.6	98.1	0.12
	40	49	2.93	73.8	0.10	64	3.78	77.9	0.10	80	4.68	82.4	0.11	93	5.41	86.3	0.11
HHP2-?-20-3-# 3 Pass Heater	10	143	34.0	100.3	1.84	175	41.2	109.5	2.56	208	48.3	118.6	3.39	241	55.2	127.7	4.27
	20	109	13.0	90.9	0.41	143	16.9	100.4	0.58	177	20.6	109.9	0.77	211	24.2	119.4	0.99
	40	52	3.10	74.6	0.14	72	4.27	80.5	0.16	116	6.83	93.0	0.20	152	8.82	103.0	0.25
HHP2-?-20-5-# 5 Pass Heater	10	157	37.2	99.5	9.08	189	44.5	107.7	12.6	ΔP > 15 PSI, use a 3 pass model				ΔP > 15 PSI, use a 3 pass model			
	20	131	15.7	93.3	1.88	165	19.5	101.7	2.71	199	23.1	110.1	3.66	232	26.7	118.5	4.73
	40	80	4.82	80.6	0.32	118	6.98	90.0	0.51	153	8.96	98.9	0.72	188	10.9	107.7	0.97
HHP2-?-24-1-#* 1 Pass Heater	10	151	35.8	89.8	0.30	199	46.7	99.3	0.33	247	57.4	108.8	0.38	294	67.6	118.2	0.43
	20	81	9.72	76.1	0.24	104	12.2	80.5	0.24	164	19.2	92.5	0.25	215	24.8	102.5	0.27
	40	68	4.08	73.4	0.23	89	5.26	77.6	0.23	111	6.51	82.0	0.24	130	7.54	85.7	0.24
HHP2-?-24-3-# 3 Pass Heater	10	204	48.6	100.5	3.54	250	58.8	109.5	4.88	295	68.6	118.5	6.43	341	78.2	127.4	8.06
	20	161	19.2	92.0	0.82	208	24.6	101.3	1.13	255	29.7	110.6	1.50	302	34.8	119.8	1.90
	40	78	4.65	75.5	0.27	124	7.37	84.8	0.33	178	10.4	95.4	0.41	227	13.1	105.1	0.50
HHP2-?-24-5-# 5 Pass Heater	10	220	52.2	103.5	13.9	ΔP > 15 PSI, use a 3 pass model				ΔP > 15 PSI, use a 3 pass model				ΔP > 15 PSI, use a 3 pass model			
	20	188	22.4	97.3	3.05	234	27.6	106.4	4.29	280	32.6	115.4	5.55	326	37.5	124.5	7.12
	40	127	7.61	85.3	0.65	175	10.4	94.8	0.92	223	13.1	104.2	1.10	270	15.7	113.6	1.47
HHP2-?-24-7-# 7 Pass Heater	10	ΔP > 15 PSI, use a 5 pass model				ΔP > 15 PSI, use a 5 pass model				ΔP > 15 PSI, use a 3 pass model				ΔP > 15 PSI, use a 3 pass model			
	20	203	24.2	96.6	8.33	249	29.3	104.9	11.7	ΔP > 15 PSI, use a 5 pass model				ΔP > 15 PSI, use a 5 pass model			
	40	150	8.98	87.3	1.44	198	11.7	96.0	2.22	245	14.4	104.5	3.14	293	17.0	113.0	4.17
HHP2-H-30-1-#* 1 Pass Heater	10	255	57.5	91.7	0.98	325	73.2	100.4	1.55	393	88.5	108.9	2.24	462	103.8	117.4	3.05
	20	124	14.0	75.4	0.06	154	17.4	79.2	0.09	277	31.1	94.4	0.28	348	39.1	103.2	0.44
	40	106	6.00	73.2	0.01	134	7.57	76.7	0.02	164	9.22	80.4	0.03	194	10.9	84.2	0.04
HHP2-H-30-3-# 3 Pass Heater	10	333	75.2	101.4	4.91	402	90.5	109.9	6.89	470	105.7	118.4	9.19	539	121.1	126.9	11.8
	20	274	30.9	94.0	0.91	344	38.7	102.7	1.36	412	46.4	111.2	1.88	480	54.0	119.7	2.49
	40	111	6.3	73.8	0.05	234	13.2	89.1	0.18	306	17.2	97.8	0.29	374	21.1	106.5	0.42
HHP2-H-30-5-# 5 Pass Heater	10	ΔP > 15 PSI, use a 3 pass model				ΔP > 15 PSI, use a 3 pass model				ΔP > 15 PSI, use a 3 pass model				ΔP > 15 PSI, use a 3 pass model			
	20	306	34.5	98.1	3.65	375	42.3	106.7	5.21	443	49.9	115.2	7.02	512	57.5	123.7	9.10
	40	220	12.4	87.4	0.56	290	16.3	96.2	0.89	360	20.2	104.8	1.29	428	24.1	113.4	1.76
HHP2-H-30-7-# 7 Pass Heater	10	ΔP > 15 PSI, use a 3 pass model				ΔP > 15 PSI, use a 3 pass model				ΔP > 15 PSI, use a 3 pass model				ΔP > 15 PSI, use a 3 pass model			
	20	321	36.2	99.9	10.3	390	43.9	108.4	14.5	ΔP > 15 PSI, use a 5 pass model				ΔP > 15 PSI, use a 5 pass model			
	40	246	13.9	90.5	1.76	316	17.8	99.2	2.69	385	21.7	107.8	3.80	454	25.5	116.3	5.07

- * HHP2 single-pass heaters are not recommended for liquid service. In most cases, a smaller multi-pass heater would be more economical.
- If using 50 Hz power supply, derate output values by 6%.
- The above figures are based on calculations at sea level.
- † Mixing ratio of ethylene glycol with water is by weight.
- ? Select "H" for Horizontal or "V" for Vertical projection on 12 to 24 inch fan sizes.
- # Refer to Page 4 to complete model code for ordering.

Glycol Performance Tables - 60% Propylene Glycol†, 60°F EAT @ 60 Hz

Model		Entering Glycol Temperature															
		180°F				200°F				220°F				240°F			
		ΔT °F	Output 10 ³ Btu/Hr	FLOW USGPM	FAT °F	ΔP PSI	Output 10 ³ Btu/Hr	FLOW USGPM	FAT °F	ΔP PSI	Output 10 ³ Btu/Hr	FLOW USGPM	FAT °F	ΔP PSI	Output 10 ³ Btu/Hr	FLOW USGPM	FAT °F
HHP2-?-12-1-# 1 Pass Heater	10	21	4.84	78.6	0.01	26	5.93	82.8	0.01	31	7.11	87.3	0.01	82	9.81	97.2	0.02
	20	19	2.19	76.7	0.00	23	2.71	80.8	0.00	28	3.28	85.2	0.00	34	3.87	89.9	0.00
	40	16	0.93	74.2	0.00	20	1.18	78.1	0.00	25	1.45	82.4	0.00	30	1.74	86.9	0.00
HHP2-?-12-3-# 3 Pass Heater	10	37	8.55	92.9	0.17	50	11.5	104.5	0.29	63	14.5	116.2	0.43	76	17.5	127.8	0.59
	20	21	2.38	78.2	0.02	26	3.00	83.2	0.02	40	4.58	95.5	0.05	54	6.22	108.4	0.08
	40	17	0.97	75.0	0.00	21	1.23	79.1	0.01	26	1.51	83.3	0.01	31	1.8	87.9	0.01
HHP2-?-16-1-#* 1 Pass Heater	10	34	7.84	78.5	0.02	42	9.61	82.7	0.03	64	14.9	94.9	0.07	87	20.0	107.3	0.12
	20	31	3.54	76.7	0.00	38	4.39	80.7	0.01	46	5.3	85.1	0.01	55	6.25	89.7	0.01
	40	26	1.50	74.1	0.00	33	1.92	78.1	0.00	41	2.35	82.3	0.00	49	2.82	86.8	0.00
HHP2-?-16-3-# 3 Pass Heater	10	68	15.8	97.4	0.41	89	20.4	108.4	0.65	109	25.1	119.5	0.92	129	29.6	130.5	1.23
	20	33	3.85	78.1	0.03	57	6.56	91.1	0.08	80	9.20	103.7	0.14	102	11.7	115.7	0.21
	40	27	1.58	75.0	0.01	35	2.00	79.0	0.01	42	2.44	83.2	0.01	51	2.93	87.9	0.02
HHP2-?-16-5-# 5 Pass Heater	10	80	18.5	103.5	2.07	99	22.9	114.2	3.01	119	27.4	124.8	4.08	138	31.7	135.3	5.25
	20	58	6.68	91.3	0.32	78	9.05	102.6	0.53	99	11.4	113.9	0.78	120	13.7	125.2	1.07
	40	29	1.66	75.5	0.03	36	2.09	79.6	0.04	54	3.12	89.4	0.07	81	4.68	104.2	0.15
HHP2-?-20-1-#* 1 Pass Heater	10	53	12.3	75.0	0.05	91	21.1	85.6	0.14	131	30.2	96.8	0.27	170	39.2	108.0	0.45
	20	48	5.53	73.4	0.01	60	6.88	76.8	0.02	72	8.32	80.3	0.02	86	9.83	84.1	0.03
	40	40	2.34	71.4	0.00	52	2.99	74.6	0.00	64	3.68	78.0	0.00	77	4.42	81.7	0.01
HHP2-?-20-3-# 3 Pass Heater	10	128	29.6	96.0	1.18	163	37.5	106.0	1.80	198	45.6	115.9	2.52	233	53.4	125.7	3.34
	20	58	6.77	76.6	0.08	116	13.3	92.7	0.26	153	17.6	103.2	0.42	191	21.9	113.9	0.61
	40	43	2.47	72.1	0.02	54	3.14	75.3	0.02	70	4.04	79.9	0.03	103	5.94	89.3	0.06
HHP2-?-20-5-# 5 Pass Heater	10	145	33.6	100.9	5.42	179	41.3	110.5	7.76	213	49.1	120.1	10.42	247	56.6	129.5	13.4
	20	111	12.8	91.1	0.90	146	16.9	101.1	1.44	182	21.0	111.2	2.08	218	25	121.3	2.81
	40	45	2.60	72.6	0.06	65	3.73	78.1	0.10	119	6.86	93.4	0.27	158	9.06	104.2	0.43
HHP2-?-24-1-#* 1 Pass Heater	10	74	17.2	74.6	0.09	153	35.3	90.2	0.37	206	47.4	100.7	0.65	261	59.8	111.6	1.01
	20	66	7.7	73.2	0.02	83	9.57	76.4	0.03	100	11.6	79.9	0.04	135	15.5	86.7	0.07
	40	56	3.26	71.1	0.00	72	4.16	74.3	0.01	89	5.12	77.6	0.01	107	6.16	81.2	0.01
HHP2-?-24-3-# 3 Pass Heater	10	186	43.1	96.9	2.31	235	54.1	106.6	3.43	284	65.3	116.3	4.75	332	76.2	125.8	6.22
	20	111	12.80	82.1	0.25	175	20.2	95.0	0.54	227	26.1	105.0	0.84	279	31.9	115.3	1.19
	40	59	3.44	71.8	0.03	79	4.56	75.7	0.04	106	6.12	81.2	0.06	171	9.81	94.0	0.13
HHP2-?-24-5-# 5 Pass Heater	10	210	48.6	101.6	0.32	258	59.3	111.0	12.5	ΔP > 15 PSI, use a 3 pass model				ΔP > 15 PSI, use a 3 pass model			
	20	166	19.3	93.0	1.59	216	24.9	102.8	2.45	266	30.5	112.6	3.45	315	36.1	122.3	4.58
	40	63	3.67	72.6	0.09	127	7.35	85.3	0.27	186	10.7	97.0	0.51	240	13.8	107.6	0.77
HHP2-?-24-7-# 7 Pass Heater	10	ΔP > 15 PSI, use a 5 pass model				ΔP > 15 PSI, use a 5 pass model				ΔP > 15 PSI, use a 3 pass model				ΔP > 15 PSI, use a 3 pass model			
	20	184	21.3	96.4	4.70	233	26.9	106.0	6.92	281	32.4	115.5	9.46	329	37.9	125.0	12.30
	40	96	5.58	78.9	0.42	166	9.58	92.6	1.05	217	12.5	102.8	1.64	269	15.4	112.9	2.31
HHP2-H-30-1-#* 1 Pass Heater	10	190	44.0	83.6	0.56	272	62.8	93.9	1.12	354	81.5	104.0	1.86	436	100.0	114.3	2.76
	20	101	11.7	72.5	0.04	126	75.6	75.6	0.06	169	19.6	81.0	0.11	273	31.3	94.0	0.28
	40	85	4.94	70.6	0.01	109	6.31	73.6	0.01	135	7.77	76.8	0.02	162	9.33	80.2	0.03
HHP2-H-30-3-# 3 Pass Heater	10	308	71.4	98.3	4.49	383	88.3	107.7	6.54	458	105.2	116.9	8.87	531	121.7	126.0	11.50
	20	228	26.4	88.3	0.70	305	35.2	98.0	1.16	384	44.3	107.8	1.71	463	53.1	117.5	2.34
	40	90	5.23	71.2	0.04	115	6.63	74.2	0.06	238	13.7	89.5	0.20	322	18.5	99.9	0.33
HHP2-H-30-5-# 5 Pass Heater	10	ΔP > 15 PSI, use a 3 pass model				ΔP > 15 PSI, use a 3 pass model				ΔP > 15 PSI, use a 3 pass model				ΔP > 15 PSI, use a 3 pass model			
	20	276	31.9	94.3	3.31	351	40.5	103.6	4.93	427	49.2	113	6.79	502	57.5	122.3	8.86
	40	99	5.74	72.3	0.17	240	13.9	89.8	0.71	320	18.4	100.0	1.12	401	23.0	109.7	1.61
HHP2-H-30-7-# 7 Pass Heater	10	ΔP > 15 PSI, use a 3 pass model				ΔP > 15 PSI, use a 3 pass model				ΔP > 15 PSI, use a 3 pass model				ΔP > 15 PSI, use a 3 pass model			
	20	298	34.3	97.0	9.24	372	42.9	106.3	13.30	ΔP > 15 PSI, use a 5 pass model				ΔP > 15 PSI, use a 5 pass model			
	40	202	11.7	85.0	1.31	279	16.1	94.6	2.22	357	20.6	104.3	3.30	435	25	114.0	4.54

- * HHP2 single-pass heaters are not recommended for liquid service. In most cases, a smaller multi-pass heater would be more economical.
- If using 50 Hz power supply, derate output values by 6%.
- The above figures are based on calculations at sea level.
- † Mixing ratio of ethylene glycol with water is by weight.
- ? Select "H" for Horizontal or "V" for Vertical projection on 12 to 24 inch fan sizes.
- # Refer to Page 4 to complete model code for ordering.

HHP2 Engineering Specifications

1.0 General

- 1.1 Heat-exchanger unit heater(s) shall be supplied and installed in accordance with the plans and specifications and shall be Hazloc Heaters' HHP2 series.
- 1.2 The unit heater(s) shall be (select one):
- suitable for steam applications operating @ _____ psi, producing _____ MBH @ entering air temperature of _____ °F and @ an altitude of _____ feet.
 - suitable for _____ (type of fluid) producing _____ MBH @ entering fluid temperature of _____ °F, exiting fluid temperature of _____ °F, entering air temperature of _____ °F and @ an altitude of _____ feet.
- 1.3 The unit heater(s) shall be (select one):
- Horizontal projection type
 - Vertical projection type

2.0 Heat Exchanger

- 2.1 The heat exchanger shall be constructed of carbon-steel headers conforming to ASME requirements with 5/8 in. (15.9 mm) outside diameter [16-gauge, 0.065 in. (1.6 mm) wall thickness] carbon-steel tubes with 1-1/2 in. (38.1 mm) outside diameter copper-free, L-foot, tension-wound aluminum fins @ 10 fins per in.
- 2.2 Inlet and outlet connections shall be (select one):
- 1-1/2 in. NPT male Sch. 40 extra heavy-duty carbon steel type
 - 1-1/2 in. CL300# RF flange (4 bolt)
 - 2 in. CL300# RF flange (8 bolt) [see ^ symbol on Page 4 for description]
- 2.3 The heat exchanger shall be suitable for pressures up to 450 psi (3103 kPa) and an operating temperature of 550°F (288°C).

3.0 Cabinet Assembly

- 3.1 The cabinet assembly shall be of a bolt together design using minimum 14 gauge, 0.075 in. (1.9 mm) steel with a yellow baked epoxy/polyester powder coating.
- 3.2 Louver blades shall be individually adjustable and made of anodized extruded aluminum.

4.0 Discharge Type

- 4.1 The unit heater(s) shall have (select one):
- One-way adjustable louvers
 - Two-way adjustable louvers (12 to 24 inch fan size only)
 - Nozzle (12 to 24 inch fan size only)
 - Four-way adjustable louvers (12 to 24 inch fan size only)

5.0 Fan and Motor Assembly

- 5.1 The fan shall be an accurately balanced propeller design with spark-resistant aluminum blades riveted to a steel hub, driven directly by the motor or speed reducer on 30" model. The fan shroud shall be spark-resistant aluminum compliant to AMCA 99-10, Type B.
- 5.2 The fan shall be shielded with a heavy-duty steel wire, epoxy-coated guard. To provide easy maintenance and cleaning of the fan and motor, the fan guard shall be of a two piece construction. The guard shall not allow a 3/8 in. (9.5 mm) probe to enter.
- 5.3 The motor shall be heavy-duty industrial type with permanently lubricated ball bearings, and be UL Listed and/or CSA Certified. The motor shall provide a method for easy field replacement of fan blade assembly without the use of specific tools.
- The motor shall be (select one):
- General purpose and rated for _____ volt, _____ phase, _____ hertz service.
 - Hazardous location rated for _____ volt, _____ phase, _____ hertz service, Class _____, Div. (Zone) _____, Group(s) _____. Temp. Code _____.

6.0 Options

- 6.1 The heater shall include the following option (select one):
- Heresite coated core (H1)
 - Heresite coated cabinet (H2)
 - Heresite coated core & cabinet (H3)

Additional Products Available

Hazloc Heaters™ offers a wide variety of steam/hydronic air heaters, explosion-proof electric air heaters, washdown/corrosion resistant air heaters, non-hazardous area air heaters, air sensing thermostats, disconnect switches and other related accessories.

Please visit www.HazlocHeaters.com and click on the *Products* link.

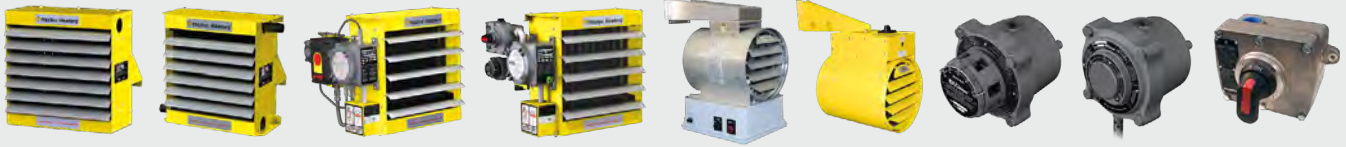

 **Hazloc Heaters™** *“Safe heat when you need it!”*

Quality Mission Statement

Quality is... customers that come back, and products that don't.

Limited 18-Month Warranty

Hazloc Heaters™ warrants all **HHP2** series of heat-exchanger unit heaters against defects in materials and workmanship under normal conditions of use for a period of eighteen (18) months from date of purchase based on the following terms:

1. The heater must not be modified in any way.
2. The heater must be stored, installed and used only in accordance with the owner's manual and attached data plate information.
3. Replacement parts will be provided free of charge as necessary to restore any unit to normal operating condition, provided that the defective parts be returned to us freight prepaid and that the replacement parts be accepted freight collect.
4. The complete heater may be returned to our manufacturing plant for repair or replacement (at our discretion), freight charges prepaid.
5. Contamination by dirt, dust, etc. or corrosion will not be considered as defects.
6. This warranty shall be limited to the actual equipment involved and, under no circumstances, shall include or extend to installation or removal costs, or to consequential damages or losses.

 **Hazloc Heaters™**

Safe heat when you need it!

#1, 666 Goddard Ave. NE
Calgary, Alberta T2K 5X3 Canada
Tel.: +1-403-730-2488
Fax: +1-403-730-2482
Customer Toll Free (U.S. & Canada):
+1-866-701-Heat (4328)
www.HazlocHeaters.com



Available from: