

XEU1 Heater Swivel Mounting Bracket (SMB) Installation Instructions

Ensure heater model number corresponds with the correct model and size of mounting bracket identified on the outside of packaging.

WARNING!

Refer to heater owner's manual for mounting specifications and conditions. If the heater is installed on a structure that is to be transported, provide additional support for heater during transit.
Suspended weight should not exceed 500 lbs (227 kg).

Swivel Mounting Bracket (SMB)

Note: Installer is required to supply:

- A) A method of fastening Top Mount Angle to supporting structure. If using bolts, we recommend four 3/8" diameter, grade 5 bolts.**
B) Two pieces of 1/2", schedule 40 or greater, steel pipe cut to required length and threaded on both ends.

STEP 1

Fasten 2 x Item #3 to structure or surface that will support the heater's weight (see heater owners manual for distance between mounting holes).

STEP 2

Screw one Item #2 and one Item #1 onto each steel pipe until tight (minimum 5 turns). Pipe lengths will vary depending on angle of support structure.

STEP 3

Bolt Item #5 to heater using four 1/2" - 13UNC x 1-1/4" bolts and 1/2" - 13UNC flange nuts.

STEP 4

Fasten the Item #4 to the appropriate sized heater bracket using the supplied 5/8"-11 x 1-1/4".

STEP 5

Insert hanger assemblies from Step 2 into the two threaded holes on top of Item #4.

STEP 6

Hang heater from the inside of Item #3 (as shown) using two 1/2" - 13UNC x 1-1/4" bolts, 1/2"-13UNC flange nuts, and 1/2"-13UNC lock nuts. Do not back off more than 3/4 turns to align hanger with bracket.

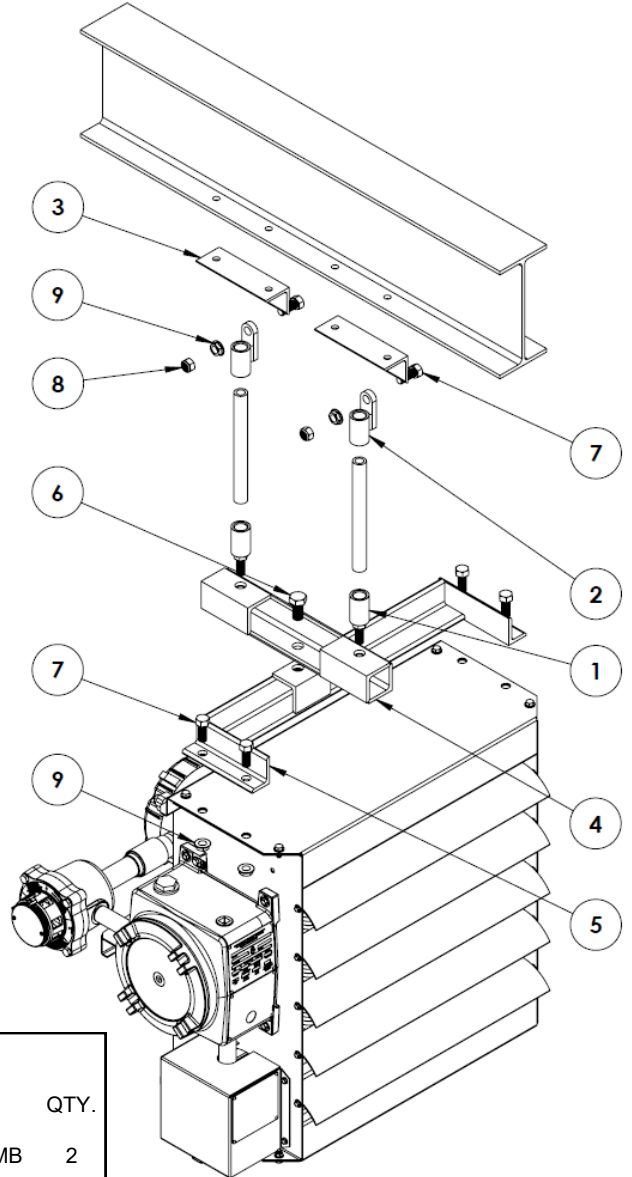

PACKAGE CONTENTS

ITEM NO.	PART	DESCRIPTION	QTY.
1	2123	BRACKET, MOUNTING, COUPLER-1/2" BOLT WELDMENT, HMB	2
2	2091	BRACKET, MOUNTING, COUPLER WELDMENT, HMB	2
3	2090	BRACKET, MOUNTING, SUPPORT STRUCTURE, HMB	2
4	2128	BRACKET, MOUNTING, ASSEMBLY, SWIVEL, ELECTRIC, SMB	1
5	*	BRACKET, MOUNTING, ASSEMBLY, HEATER, XEU, *, BMB	1
6	2122	BOLT, 5/8"-11 X 1-1/4", HEX HEAD, GR. 5, ZINC COATED	1
7	2121	BOLT, 1/2"-13 X 1-1/4" LG, HEX HEAD, GR 5, ZINC COATED	6
8	2180	NUT, LOCK, 1/2"-13 UNC, STEEL, GR 2, ZINC COATED	2
9	1284	NUT, FLANGED HEX, 1/2"-13 UNC, STEEL, GR 2, ZINC PLATED	6

* 12" - 2144
 16" - 2145
 20" - 2146

