

# INSTALLATION AND OPERATION MANUAL

## XDC-01 Explosion-Proof Disconnect Switch for Hazardous Locations

The XDC-01 explosion-proof disconnect switch is designed for load isolation or motor control switch applications located in hazardous locations.

## SPECIFICATIONS

- 600 Volt A.C., 50 Amp max, three pole, non-fused switch for maximum versatility.
- NEMA Type 7 & 9 enclosure and cover are made of a copper-free aluminum alloy.
- Two 1" NPT & one 3/4" NPT openings for flexible field wiring (package includes one 3/4" & one 1" ex-proof close-up plugs).
- Two internal grounding lugs.
- Compact design, weighs only 13 lbs (5.9 kg).
- CSA<sub>C/US</sub> – Certified to Canadian and U.S. standards.

Max Horse Power Ratings	
208 Volt, 3 phase	15 HP
240 Volt, 3 phase	15 HP
480 Volt, 3 phase	30 HP
600 Volt, 3 phase	30 HP
120 Volt, 1 phase	2 HP
240 Volt, 1 phase	7.5 HP

Supply Wire Requirements	
Total Current Amps	Supply Wire 90°C (AWG)
40 – 50 MAX	6
30 – 39	8
20 - 29	10
15 – 19	12
0 – 14	14

\* Please refer to the owner's manual or data plate for the connected equipment. Always follow local safety codes.

Hazardous Location Approvals
Class I, Divisions 1 & 2, Groups C & D
Class II, Divisions 1, Groups E, F & G
Class II, Divisions 2, Groups F & G
Class III
Class I, Zones 1 & 2, Groups IIA & II B, T5

## INSTALLATION

### - WARNING! -

Read and follow the instructions in this manual. Failure to do so may result in severe or fatal injury.

- 1) The XDC-01 is to be connected and serviced only by a qualified electrician experienced with hazardous location equipment. It is the responsibility of the installer to verify the safety and suitability of the installation.
- 2) **Explosion/Electric Shock Hazard.** Disconnect power supply before installing the XDC-01.
- 3) Remove the Disconnect cover assembly from the base by removing the six (6) cover bolts. Set the cover assembly aside.  
**CAUTION: Damaging the mating surfaces of the enclosure could destroy the flame path and jeopardize the integrity of the flame proof enclosure.**
- 4) Mount the enclosure onto the surface selected. See Fig. 1 for dimensions
- 5) The enclosure has two (2) 1" NPT and one (1) 3/4" NPT entries. **Unused entries must be properly plugged with the plug provided prior to applying power to the unit.**
- 6) See Fig. 2 for wiring schematics.
- 7) **WARNING! Before attaching the cover ensure that both the cover handle and the ABB switch are in the "OFF" position.**
- 8) Attach cover to the enclosure using the six (6) bolts. **TIGHTEN TO 150 INCH POUNDS ± 5 lb.inch.**
- 9) The installer must seal each conduit run within 18" of the thermostat enclosure. This seal must be a suitable, listed hazardous location fitting.

# Figures

## Fig. 1

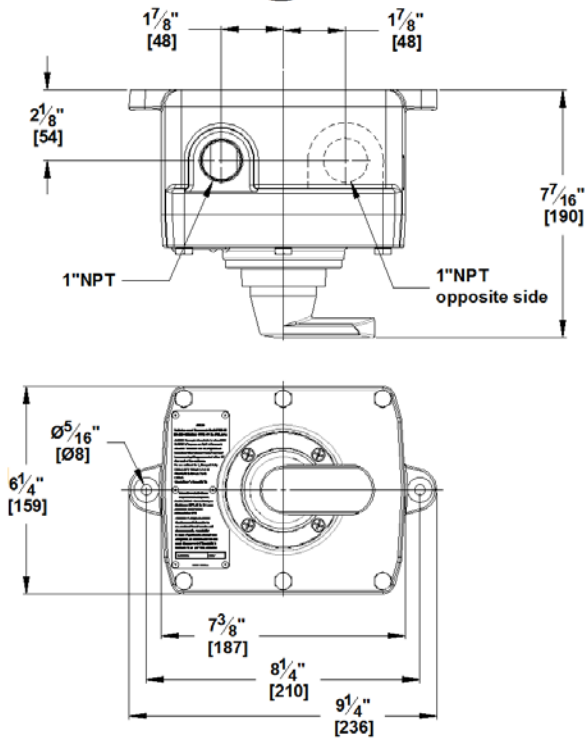

## Fig. 2

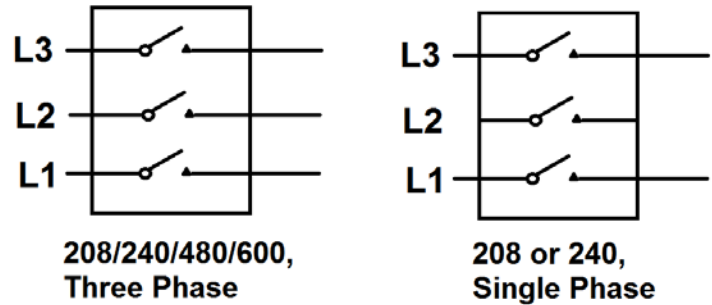

## Fig. 3

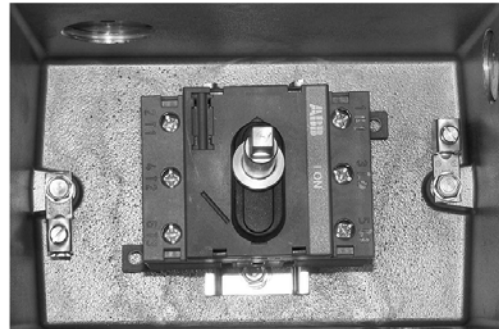

Internal view showing DIN rail mounted ABB OT63F3 non-Fusible, heavy duty, disconnect switch with dual grounding lugs and actuation shaft.

### **WARNING!**

Ensure that both the cover handle and the ABB switch are both in the "OFF" position before installing the cover.

## WARRANTY

### Limited 36-Month Warranty

The XDC-01 series of explosion-proof disconnect switches are warranted against defects in materials and workmanship under normal conditions of use for a period of thirty-six (36) months from date of purchase based on the following terms:

- 1) The disconnect switch must not be modified in any way.
- 2) The disconnect switch must be stored, installed and used only in accordance with this owner's manual and attached data plate information.
- 3) Replacement parts will be provided free of charge as necessary to restore any unit to normal operating condition, provided that the defective parts be returned to us freight prepaid and that the replacement parts be accepted freight collect.
- 4) The complete disconnect switch may be returned to our manufacturing plant for repair or replacement (at our discretion), freight charges prepaid.
- 5) Contamination by dirt, dust, etc. or corrosion will not be considered as defects.
- 6) This warranty shall be limited to the actual equipment involved and, under no circumstances, shall include or extend to installation or removal costs, or to consequential damages or losses.